

## REZBA VA UNING TURLARI.

Vint chizig'i bo'yicha biror tekis shakl (rezba profili)ning harakatlanishi natijasida rezba hosil bo'ladi. Ko'plab mashina detallari o'zaro bir-biri bilan rezbalar yordamida biriktiriladi.

**Rezba profili** keskich asbob uchining shakliga bog'liq bo'lib, u teng yonli yoki teng tomonli uchburchak, trapetsiya, to'rtburchak, kvadrat, yumaloq shakllarda bo'lishi mumkin.

Bir profilning vintsimon harakatidan hosil bo'lgan rezba **bir kirimli**, 2 profilning harakatidan hosil bo'lgan rezba **ikki kirimli**, 3 profilning harakatidan hosil bo'lgan rezba **uch kirimli rezba** deb ataladi.

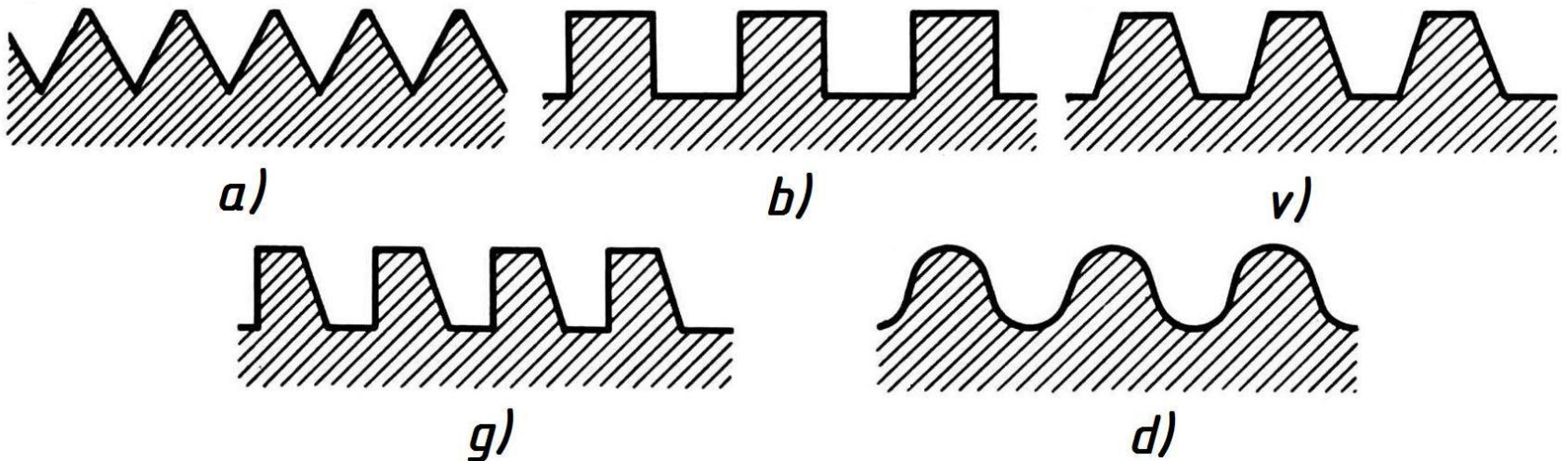

## 6-SAVOL. REZBA VA UNING TURLARI.

Qo'shni o'ramlar orasidagi yasovchi bo'ylab o'lchangan masofa *rezba qadami* deyiladi va u *P* harfi bilan belgilanadi.

Bir o'ramning o'zidagi ikki nuqta orasidagi yasovchi bo'ylab o'lchangan masofa *rezba yo'li* deyiladi va u *t* harfi bilan belgilanadi.

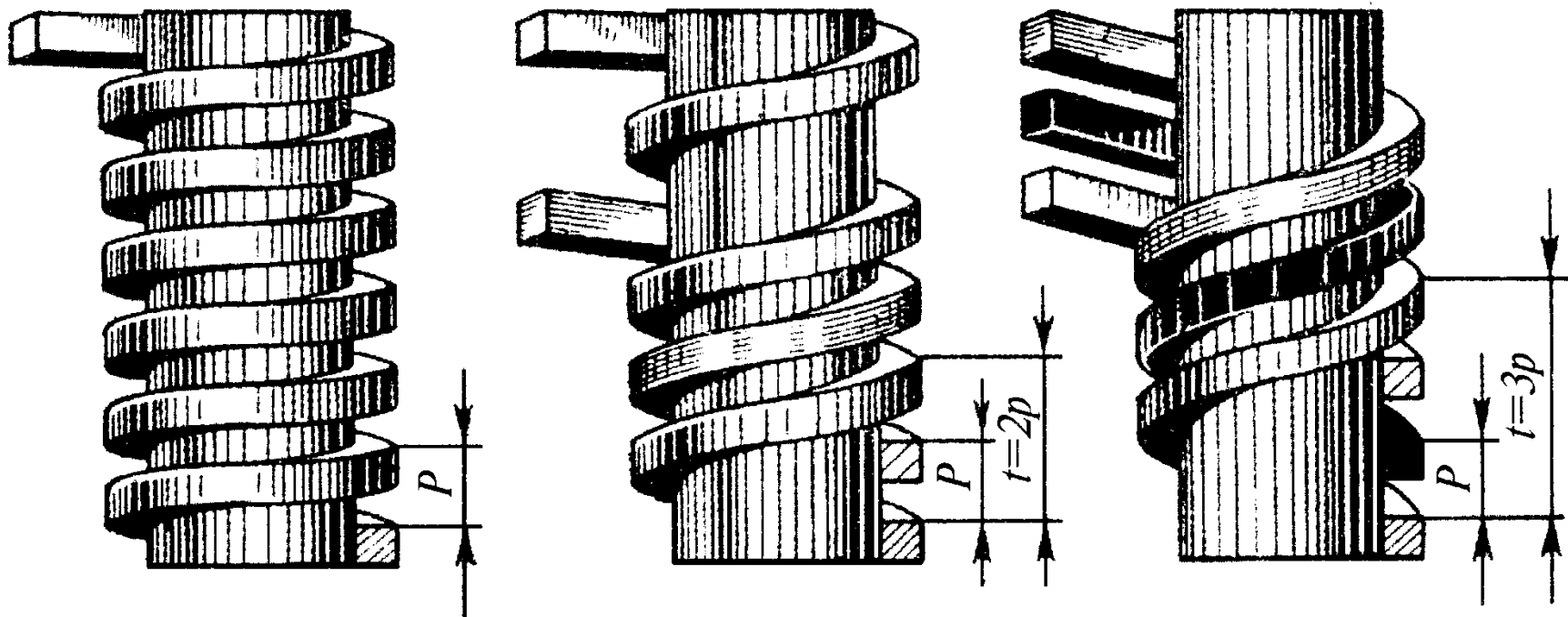

## 6-SAVOL. REZBA VA UNING TURLARI.

Texnikada sterjenga tashqi rezba ochish uchun rezba ochuvchi uskunalardan foydalaniladi.

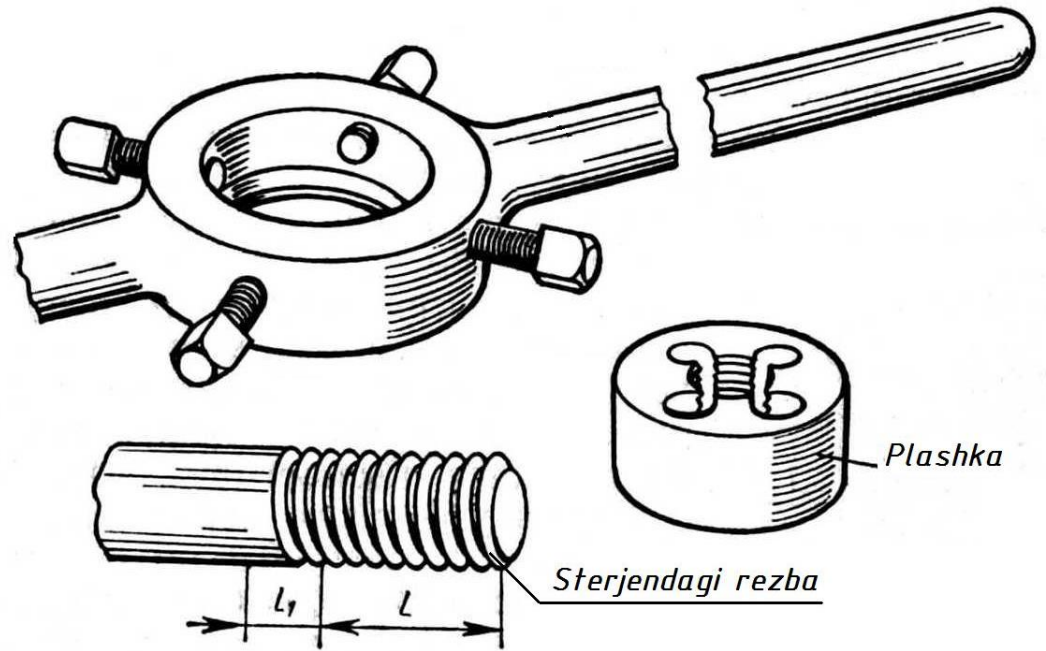

Tashqi rezba ochish uchun **plashka** va ichki rezba ochish uchun **metchik** deb ataluvchi rezba ochadigan asboblardan foydalaniladi.

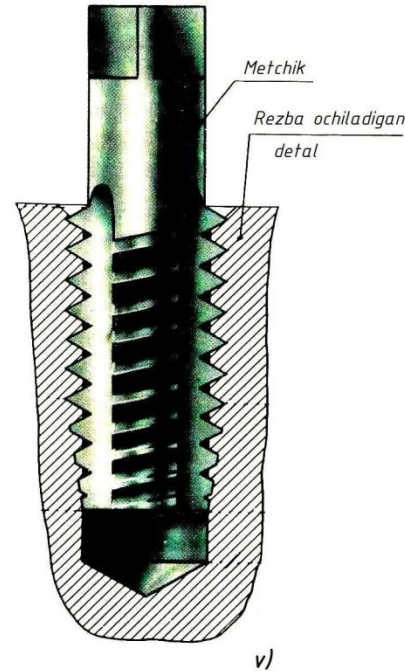
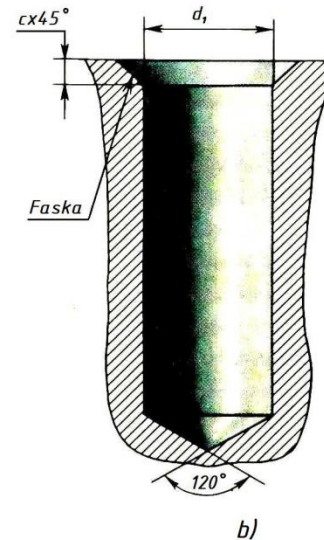
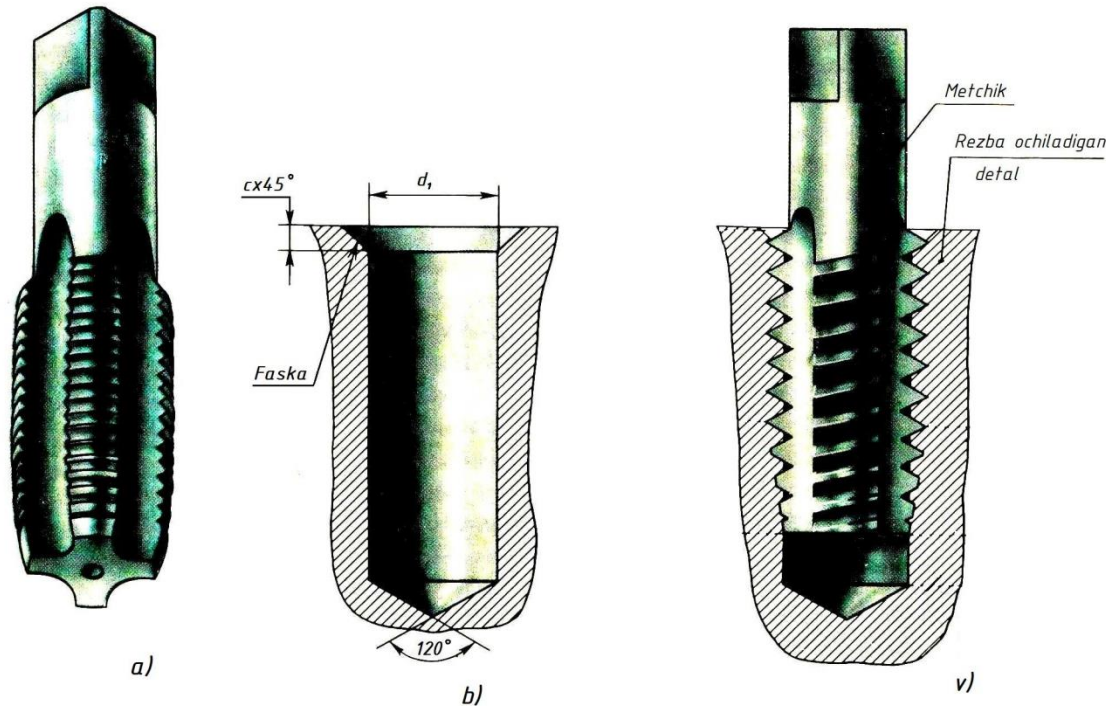

# REZBA VA UNING TURLARI.

Uchburchak profilli rezbalar *biriktirish rezbalari* deyiladi. Boshqa profilli rezbalar *yurgizish rezbalari* deyiladi. To'g'ri to'rtburchakli rezbalardan boshqa barcha rezbalar standartlashtirilgan va ular quyidagi 6 ta asosiy turdan iborat.

## 1. Metrik rezbalar.

**1.1. Silindrik metrik rezba** (GOST 8724-81 va GOST 9150-81) rezba o'zining burchak profili  $\alpha=60^\circ$  (profil teng tomonli uchburchak) bilan xarakterlanadi. Profilning nazariy balandligi  $H=0,86602 P$ , ish balandligi  $H=0,54126 P$  gat eng. Amaliyotda ko'proq diametri 1 mm dan 600 mm gacha bo'lgan silindrik metrik rezbalar tatbiq etiladi.

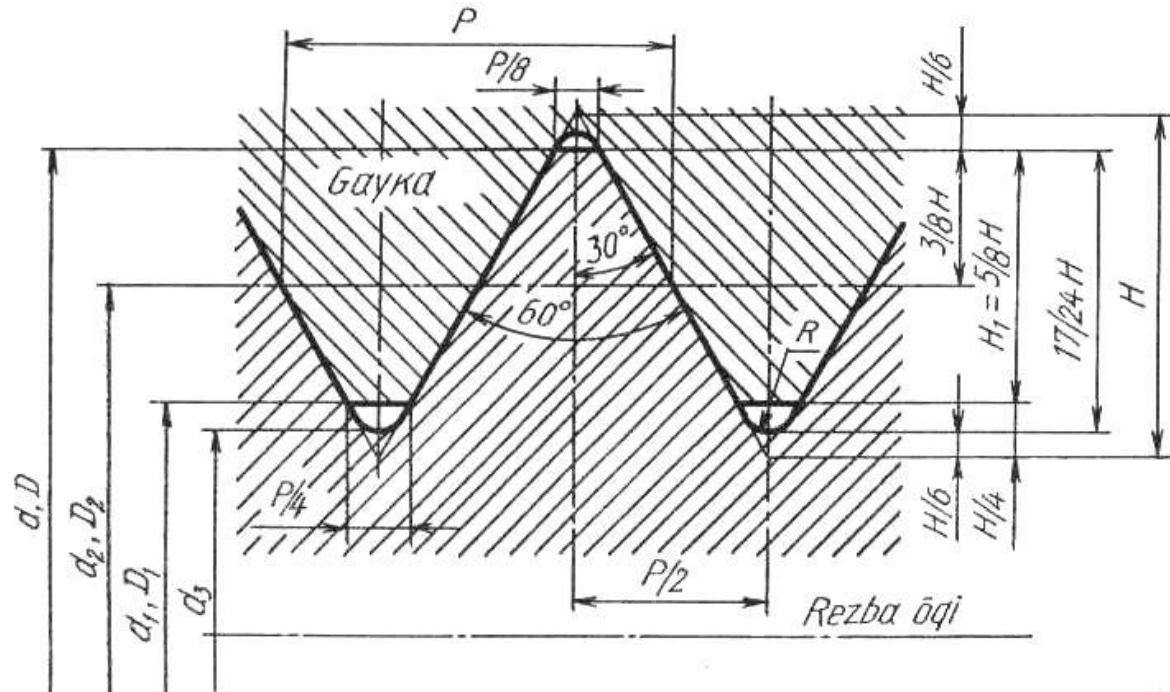

# REZBA VA UNING TURLARI.

## 2. Dyumli rezbalar.

**2.1. Silindrik dyumli rezbalar** (NKTP 1260). Bu rezbalarning tashqi diametri dyumlarda ( $1''=25,4 \text{ mm}$ ), qadami esa  $1''$  ga to'g'ri keladigan o'ramlar soni bilan belgilanadi. Dyumli rezbaning profili teng yonli uchburchaklik bo'lib, uchidagi burchagi  $55^0$  ga teng. Amalda uchburchak uchlari tekis kesilgan bo'lib, to'mtoq holda bo'ladi.

Chizmada dyumli rezbalarning faqat tashqi diametri ko'rsatiladi. Masalan,  $1\frac{1}{2}''$  bilan belgilangan rezbaning tashqi diametri  $1\frac{1}{2}''$  (yoki  $\approx 38 \text{ mm}$ ) va  $1''$  ga 6 ta o'ram (qadami  $\approx 4,23 \text{ mm}$ ) to'g'ri kelgan rezbadir.

**2.2. Konussimon dyumli rezbalar.** (GOST 6111-52\*). Bu rezbadan suv, moy, yoqilg'i va havo o'tadigan mashina va uskunalarning truba va naychalarini biriktirishda foydalaniladi. Profili teng tomonli uchburchak bo'lib, uchidagi burchagi  $60^0$  ga teng va konusligi  $K=1:16$  nisbatda bo'ladi. Rezba belgisiga rezbaning shartli belgisi " $K$ ", dyumda o'lchangan ( $1''=25,4 \text{ mm}$ ) va davlat standartiga kiradi. Masalan,  $K\frac{3}{4}''$  GOST 6111-52\*. Rezba o'lchami chiqarish chizig'i tokchasi ustiga yoziladi.

## REZBA VA UNING TURLARI.

### 3. Truba rezbalar.

**3.1. Silindrik truba rezbalar** (GOST 6357-81) suv-gaz trubalarida, ularni biriktiruvchi mufta, tirsak kabi qismlarda va shunga oxshash armaturalarda ishlatiladi. Silindrik truba rezba o'zining burchak profili  $\alpha=55^{\circ}$  (profil teng yonli uchburchak) bilan xarakterlanadi.

Truba rezbaning shartli belgisi: **G** harfi bilan belgilanadi, rezbaning dyumda ifodalangan olchami 1 yoki  $\frac{1}{2}$  (dyum «"» - belgisiz) ko'rsatiladi; orta diametrning aniqlik klassi (**A** yoki **B**) va rezbaning uzunligi (agar nostandart bolsa) olchamlari kiradi. Chapaqay rezbalar uchun esa, rezba belgisiga **LH** qoshib yoziladi.

Misollar: **G $\frac{1}{2}$  - A**; **G $1\frac{1}{2}$  LH - A**; **G  $1\frac{1}{2}$  - B - 25**; **G  $1\frac{1}{2}$  LH - B - 40**, bu yerda, **25, 40** – rezba uzunligi mm da, **A, B** – aniqlik klasslari va  **$1\frac{1}{2}$**  - rezbaning tashqi diametri olchamlari (bu erda 1"- rezba ishlangan trubaning diametri o'lchamini ifoda qiladi va u 33,25 mm (**1 dyum=33,25 mm**)ga teng.

Trubaning suv yoki gaz o'tadigan ichki teshigi diametri 25,4 mm ( **$D_{\text{I}}=25,4$  mm** bo'ladi).

# REZBA VA UNING TURLARI.

## 3. Truba rezbalar.

**3.2. Konussimon truba rezbalar** (GOST 6211-81). Bu rezbalarning profili uchburchak shaklida bo‘lib, uchidagi burchagi  $55^{\circ}$ , profilining uchlari yumaloqlangan.

Bu rezbadan yuqori issiqlik bosimi ostida ishlaydigan hamda katta zichlikni talab qiluvchi naycha va trubalar birikmasida foydalaniladi. Rezba ochiladigan detallarning konusligi  **$K=1:16$**  nisbatda yoki konus uchidagi burchagi  **$\varphi=3^{\circ}34'48''$**  ga teng bo‘ladi. Konussimon rezbaning diametri doimiy ravishda o‘zgarib turganligi sababli uning o‘lchamini asosiy tekislikdagi kesimdan olinadi.

Konussimon truba rezbalar “ $R$ ” harfi bilan, jumladan, sterjendagi tashqi truba rezba “ $R$ ”, tekislikdagi ichki konussimon “ $R_c$ ” va teshikdagi silindrik va tashqi konussimon truba rezba “ $R_p$ ” harflar bilan belgilanadi.

## **REZBA VA UNING TURLARI.**

**4. Trapetsiyasimon rezbalar (GOST 9494-81).** Bunday rezbalar ilgari qayta harakatlarni uzatuvchi vintlarda qo'llaniladi.

Trapetsiyasimon rezbalar uchun **10 mm dan 640 mm** gacha bo'lgan diametrlar belgilangan. Bunday rezbalar bir va ko'p kirimli hamda chapaqay va o'naqay qilib ishlanishi mumkin. Ko'p kirimli rezbaning muhim elementlaridan biri rezbaning yo'lidir:  $t=P \times n$ ;  $P$  – rezba qadami, mm,  $n$  – kirimlar soni.

Chizmada trapetsiyasimon rezbalar quyidagicha belgilanadi: tashqi rezbalar  **$Tr\ 50 \times 4 - 8e$  GOST 24738-81**, bu yerda  $50$  - rezba diametri,  $4$  - qadami,  $8e$  - qo'yimlar maydoni. Ichki rezbalar uchun  **$Tr\ 50 \times 4 - 8H$  GOST 24738-81**, shuning o'zi chapaqay rezba uchun  **$Tr\ 50 \times 4 LH - 8e$  GOST 24738-81**.

Ko'p kirimli rezbalarda qo'shimcha ravishda rezbaning yo'li ham ko'rsatiladi. Masalan,  **$Tr\ 50 \times 8 (P4) - 8H$  GOST 24738-81**, chapaqay rezba uchun  **$Tr\ 50 \times 8 (P4) LH - 8H$  GOST 24738-81**, rezba belgisidagi  $P4$  – qadamlar, rezbaning yo'li  $t=8\text{ mm}$ , kirimlar soni  $n=t/p=8/4=2$ .



## REZBA VA UNING TURLARI.

**5. Tirak rezbalar (GOST 10177-82).** Bu rezbalardan kuch bir tomonga yoʻnalgan moslamalarda (domkrat, press, iskanja va shu kabi siqish vintlarida) ishlatiladi. Tirak rezbalar ham bir va koʻp kirimli qilib tayyorlanadi. Tirak rezbalarga tegishli aniqlik klasslarini va dopusklar maydonini GOST 25096-82 belgilaydi. Tirak rezba “S” harfi bilan belgilanadi.

Tirak rezbalar quyidagicha belgilanadi: **S70×10-7h GOST 10177-82**, chapaqay rezba **S70×10 LH-7h GOST 10177-82**. Bu yerda **70** – rezba diametri, **10**- rezba qadami, **7h** - qoʻyimlar maydoni.

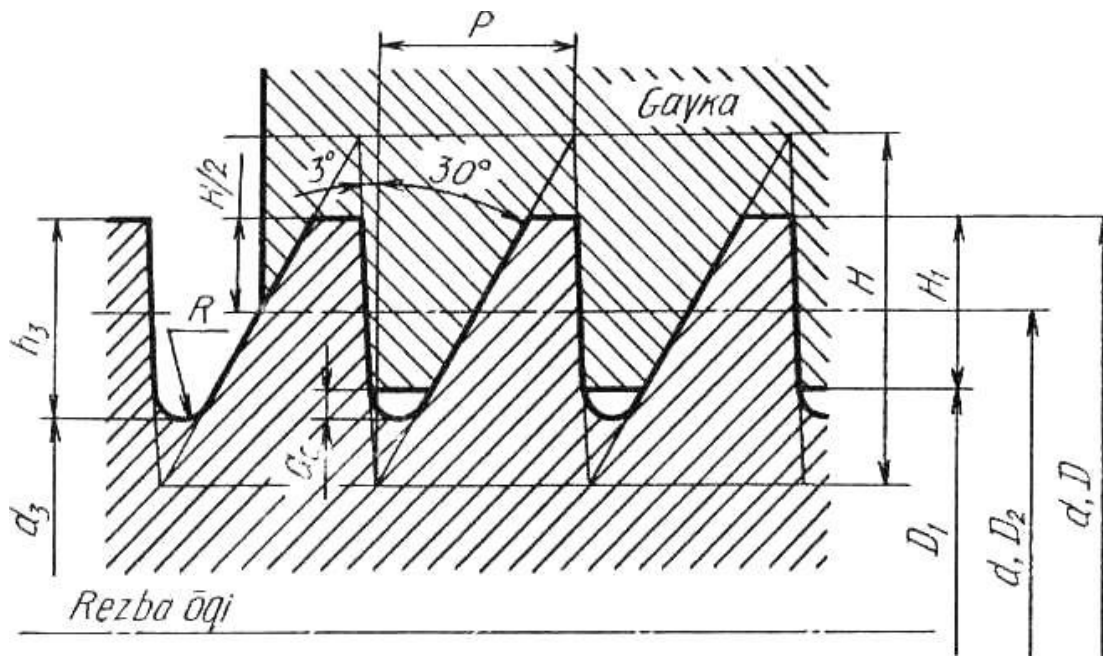

# REZBA VA UNING TURLARI.

**6. Yumaloq rezba (GOST 13536-68).** Ushbu rezbaning profili yumaloqlanganligi uchun uni *yumaloq rezba* deyiladi. Bu rezbalardan asosan santexnika, elektr-yoritish asboblarida, plastmassa va chinni buyumlarni biriktirishda foydalaniladi.

GOST 13536-68 ga muvofiq, faqat diametri  $d=12$  mm bo'lgan yumaloq rezbalar santexnika buyumlari (suv trubai va hojatxona jo'mraklari hamda qorishtirish ventillarining shpindellari) da ishlatiladi. Yumaloq rezbaning shartli belgisi "*Kr*" bo'lib, chizmada quyidagicha belgilanadi:

*Kr12×2,54* GOST 13536-68, bunda 2,54 – rezbaning qadami.

# REZBA VA UNING TURLARI.

To'g'ri burchakli rezbalar. Bu rezbalar muhim bo'lmagan joylarda masalan, ventil, zadjivka shpindellarida, domkrat, press vintlarida ishlatiladi.

Rezbaning profili standartlashtirilmagan va shartli belgiga ega emas. Chizmada rezbaning profili, ichki va tashqi diametri, qadami ko'rsatiladi.

Standart profilli rezbalarning diametri yoki qadami standart o'lchamlardan farq qilsa, *maxsus rezba* deyiladi. Bunday rezbalarning belgisiga "*Maxs*" so'zi qo'shib yoziladi.

# REZBALARNI CHIZMADA SHARTLI TASVIRLANISHI VA BELGILANISHI

*Kamida 0,8 mm*      *Rezba chegarasi*

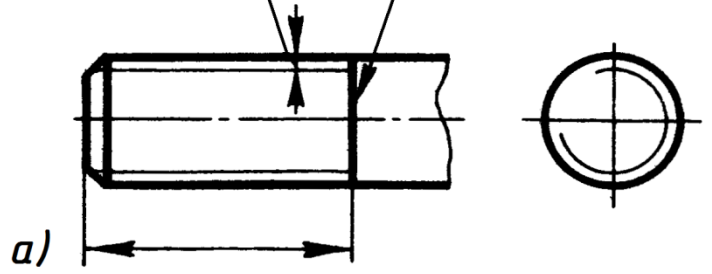

a)

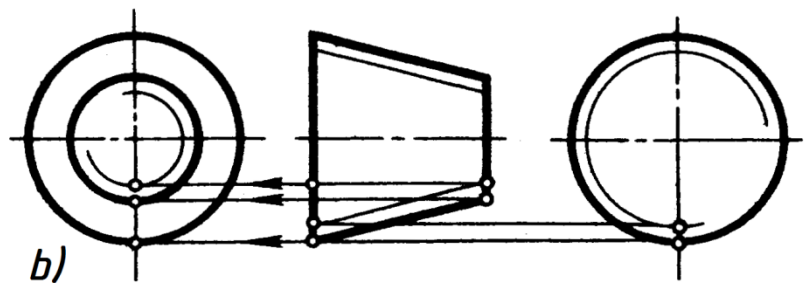

b)

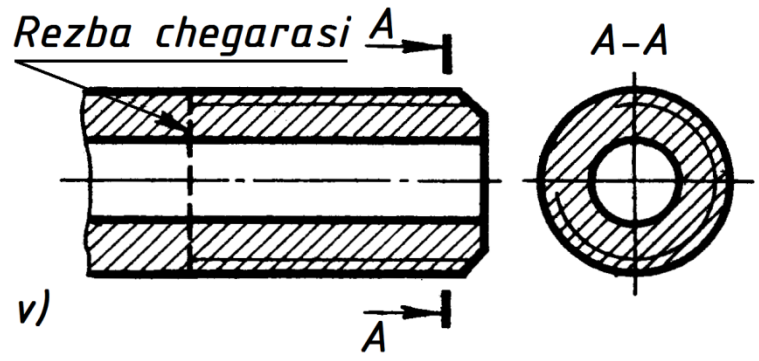

v)

*Kamida 0,8 mm*

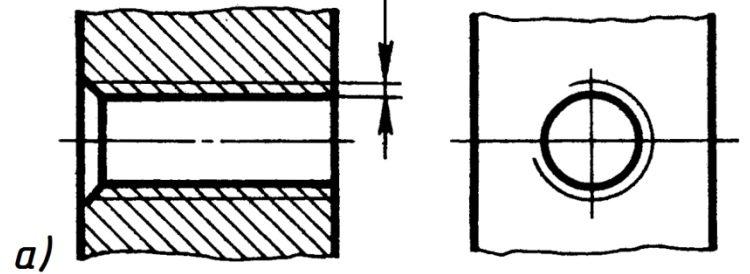

a)

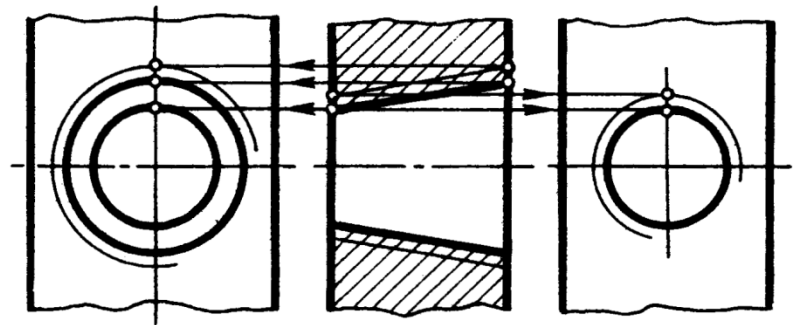

b)

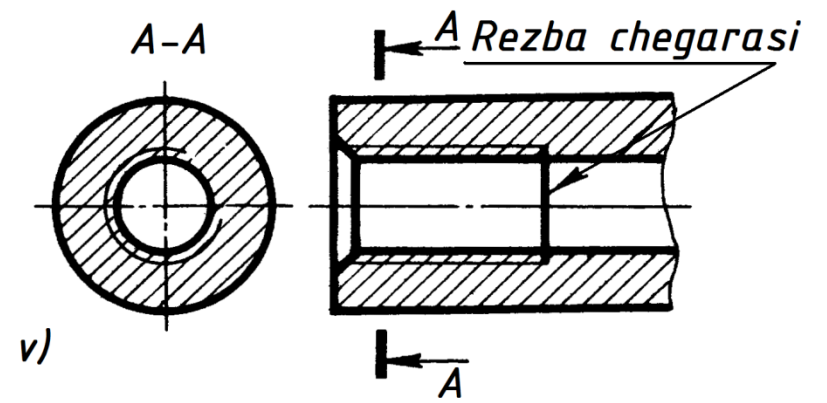

v)

# REZBALARNI CHIZMADA SHARTLI TASVIRLANISHI VA BELGILANISHI

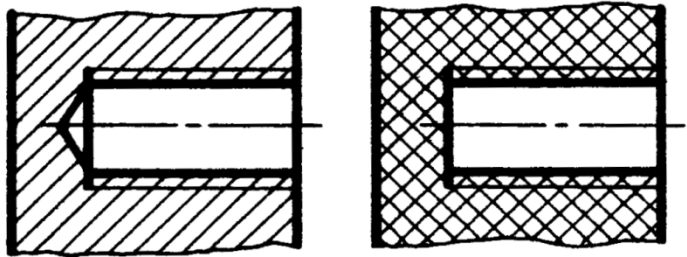

a)

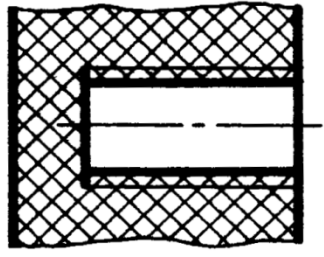

b)

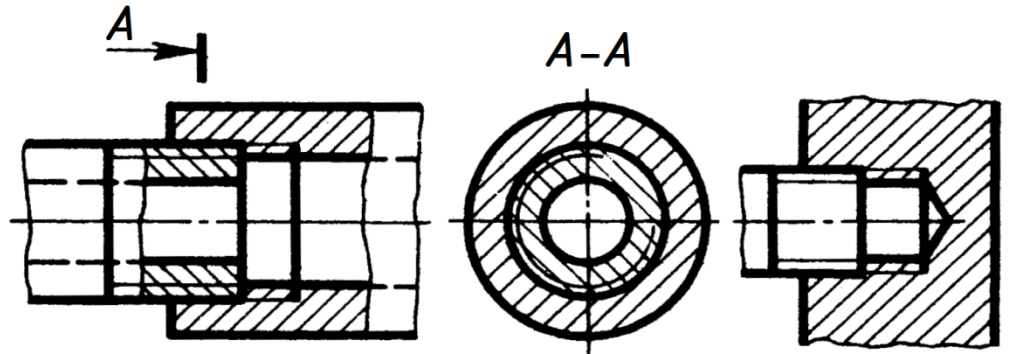

a)

b)

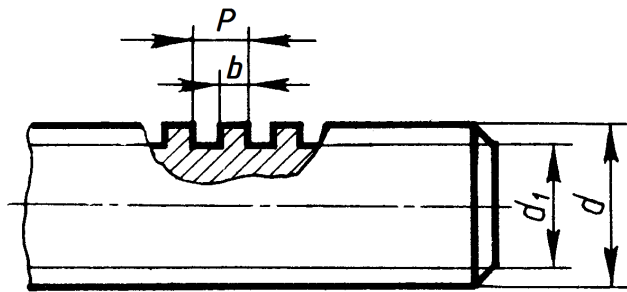

a)

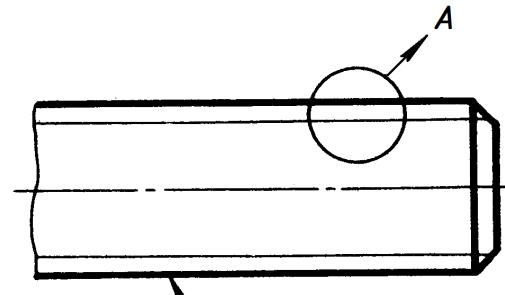

*Ikki kirimli rezba*

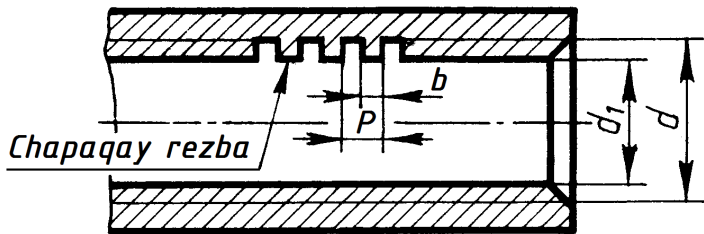

b)

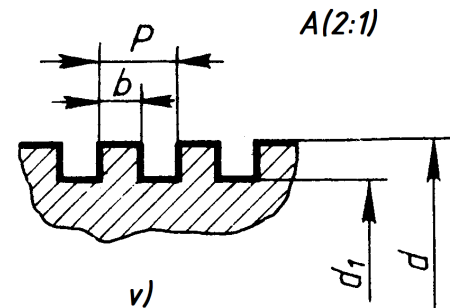

v)

# REZBALARNI CHIZMADA SHARTLI TASVIRLANISHI VA BELGILANISHI

*Rezba sbegi, protochkasi va rezbali buyumlarning faskasi.*

Rezbalarining konstruktiv va texnologik elementlari (faska, rezba sbegi, oxirigacha qirqilmagan qism, protochkalar) uchun o'lcham va shakllar aniq o'rnatilgan.

Rezba keskichining uchi detalning butun uzunligi bo'yicha kesib boradi, natijada rezba profilining oxirgi qismi kichrayib yo'q bo'lib ketadi va shu joydan keskich chiqib ketadi. Ana shu rezba profilining kichrayib, yo'q bo'lib ketgan qismi **rezbaning sbegi** deyiladi va u chizmada "X" bilan belgilanadi.

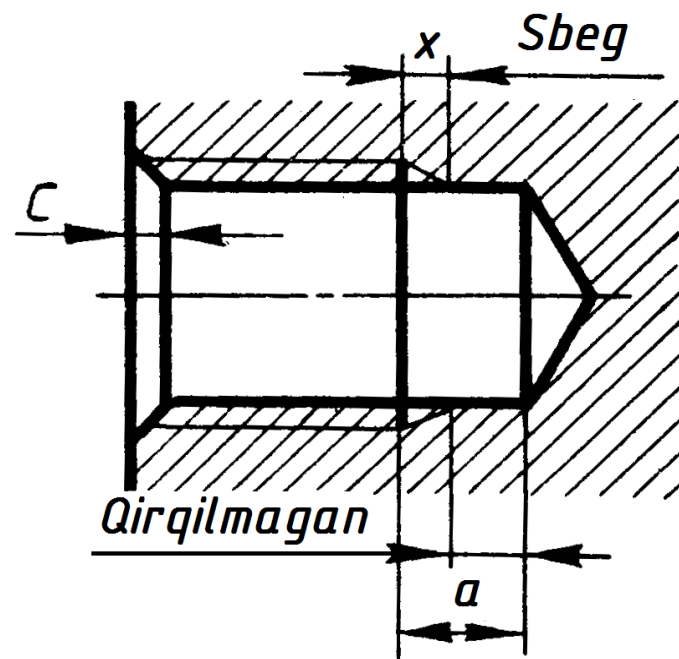
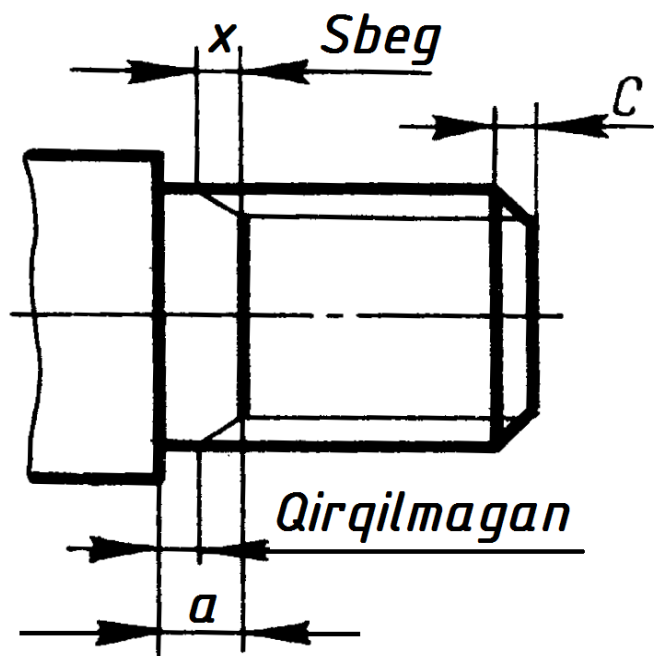

# REZBALARNI CHIZMADA SHARTLI TASVIRLANISHI VA BELGILANISHI

*Rezba sbegi, protochkasi va rezbali buyumlarning faskasi.*

Sterjen va teshikdagi rezbaning uzunlik o'lchamlari ( $L$ ) rezba sbegisiz qo'yiladi ( $a$  va  $b$ ).

Ayrim hollarda rezba uzunligi sbeg bilan qo'shib yoki sbeg va rezba uzunliklari alohida ko'rsatiladi ( $v$ ,  $g$ ).

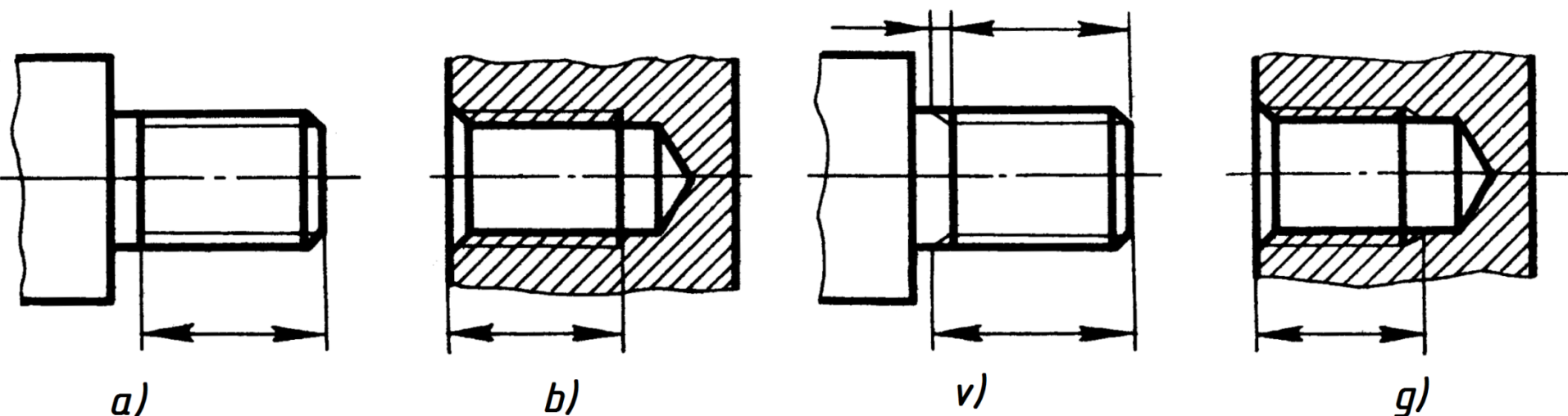

# REZBALARNI CHIZMADA SHARTLI TASVIRLANISHI VA BELGILANISHI

Rezba sbegi, protochkasi va rezbali buyumlarning faskasi.

Detallarda to'la profilli rezba hosil qilish uchun uni o'yishda sbeg qismi o'rnida **protochka** (ariqcha) o'yiladi.

Natijada rezba qir qilganda keskichning uchi rezbani o'yib borib ariqchaga chiqadi va hosil bo'lgan rezba to'la profilli bo'ladi.

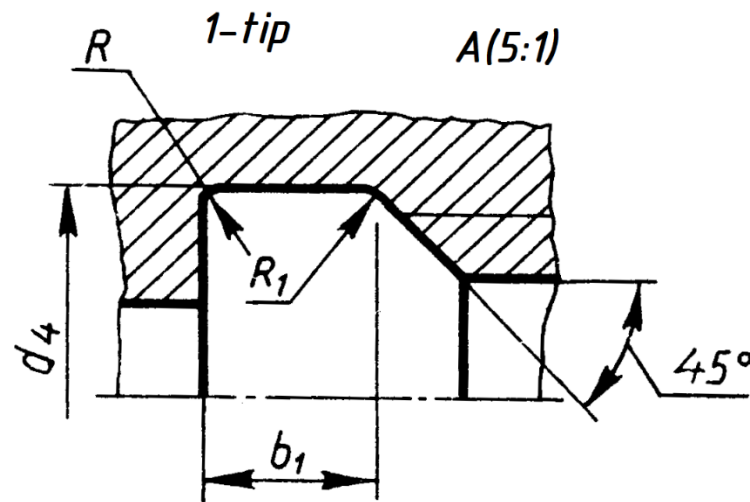
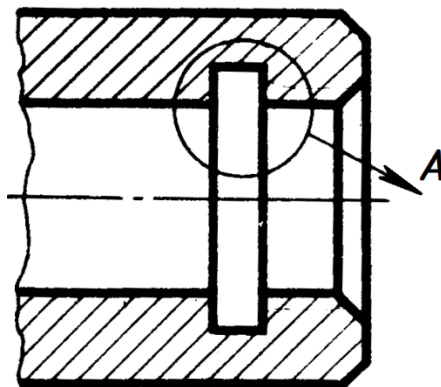
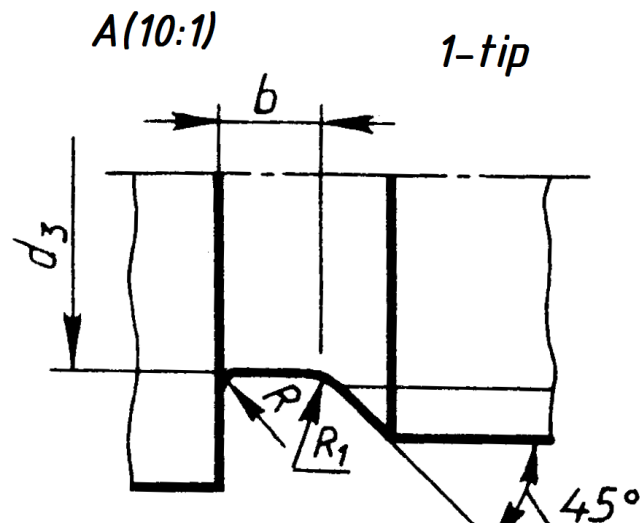
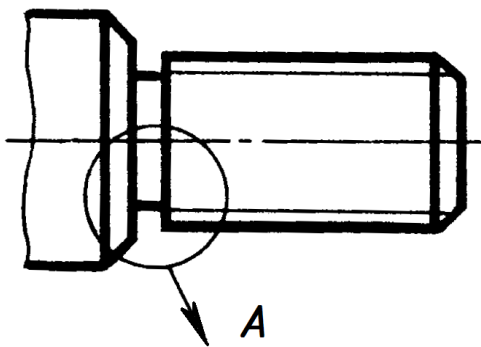



# REZBALI DETALLAR

**1. Boltlar.** Bolt silindrik sterjendan iborat bo'lib, uning bir uchi kallakli, ikkinchi uchi rezbali bo'ladi. Boltlar kallagining shakli olti qirrali, kvadrat, yarim yumaloq, konus shaklida va kallagining osti kvadratli yoki "murtakli" qilib ishlanadi. **Bolt M6x1,5 GOST 7798-70.**

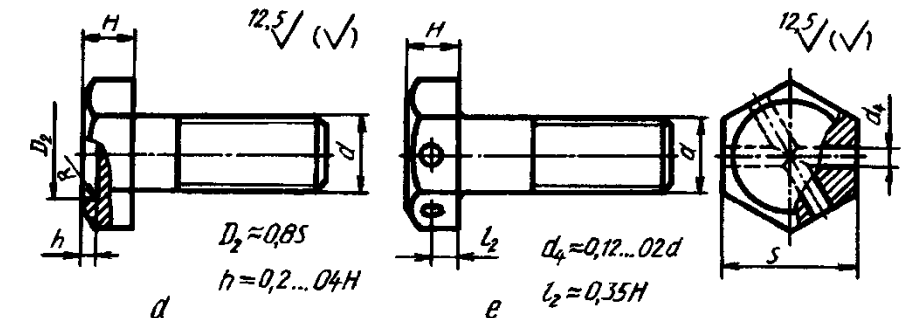
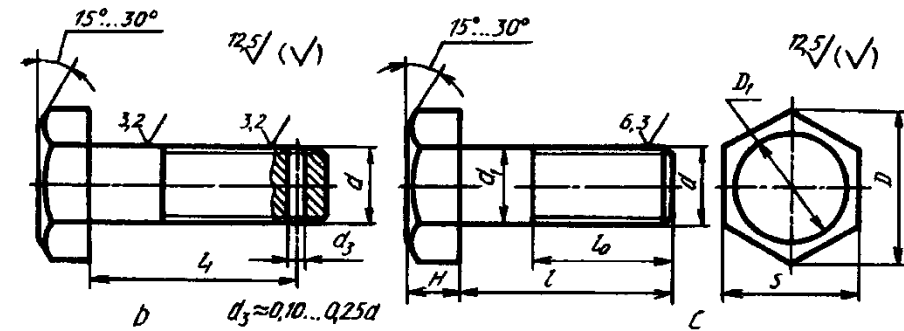
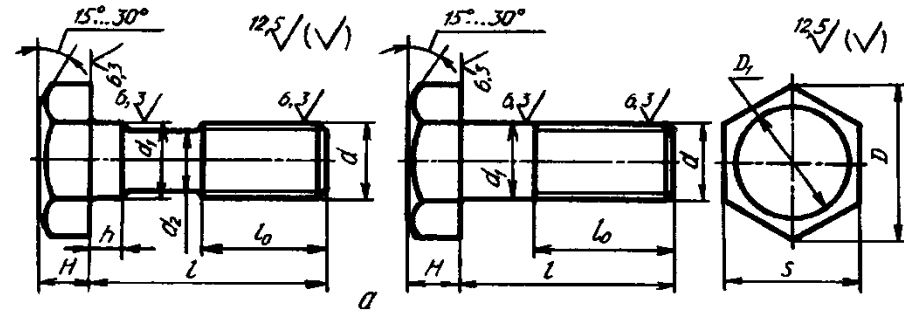
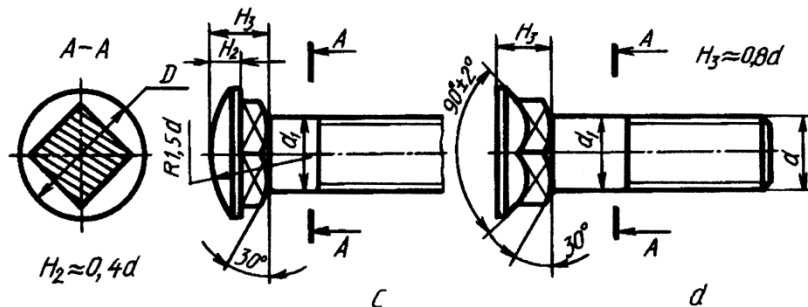
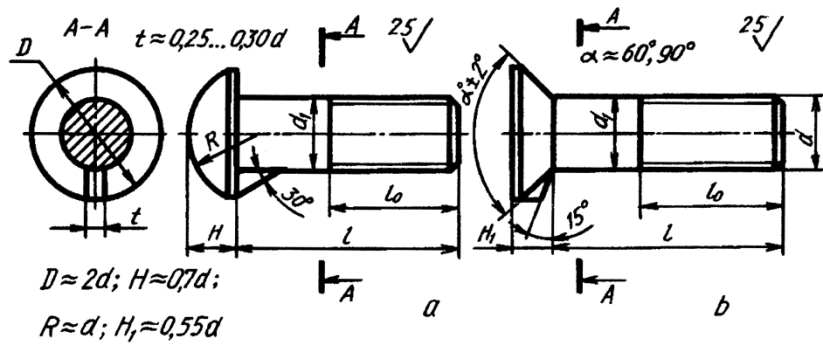
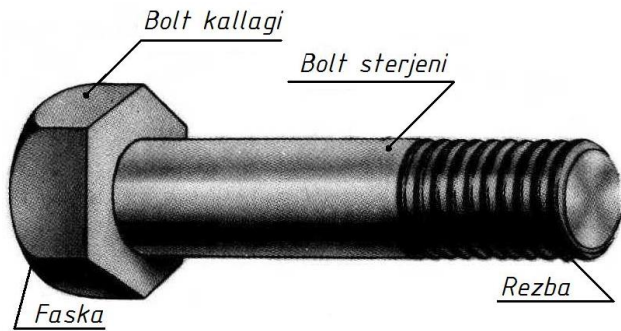

# REZBALI DETALLAR

**1. Boltlar.** Boltlarni berilgan sterjen diametriga nisbatan taxminiy olchamlarda chizish mumkin. Bolt rezbasining diametri  $d=20$  mm berilgan bo'lsa, ichki rezbasining diametri  $d_f=0,85 \times d=17$  mm, kallagining burchaklarini qamrab oluvchi aylana diametri  $D=2 \times d=40$  mm, kallagining kalitbop o'lchami yasash yo'li bilan aniqlanadi yoki  $1,73 \times d=34,6$  mm olinadi, kallagining balandligi  $H=0,7 \times d=14$  mm, rezbasining uzunligi  $l_0=2d+6=46$  mm, faskasi  $c=0,15 \times d=3$  mm, bolt kallagi burchaklarining uchlaridagi burchagi  $120^\circ$  li konusli faska bilan kesishishidan hosil bo'lgan yoqlardagi giperbolalar o'rniga  $R=1,5 \times d=30$  mm va  $R_1=d=20$  mm radiusli aylana yoqlarida chiziladi. Boltning uzunligi  $l$  (bolt kallagi  $H$  uning uzunligiga kirmaydi) biriktiriluvchi detallarning qalinliklariga bog'liq bo'ladi, ya'ni  $H_1+H_2+1,3 \times d$  olinadi.

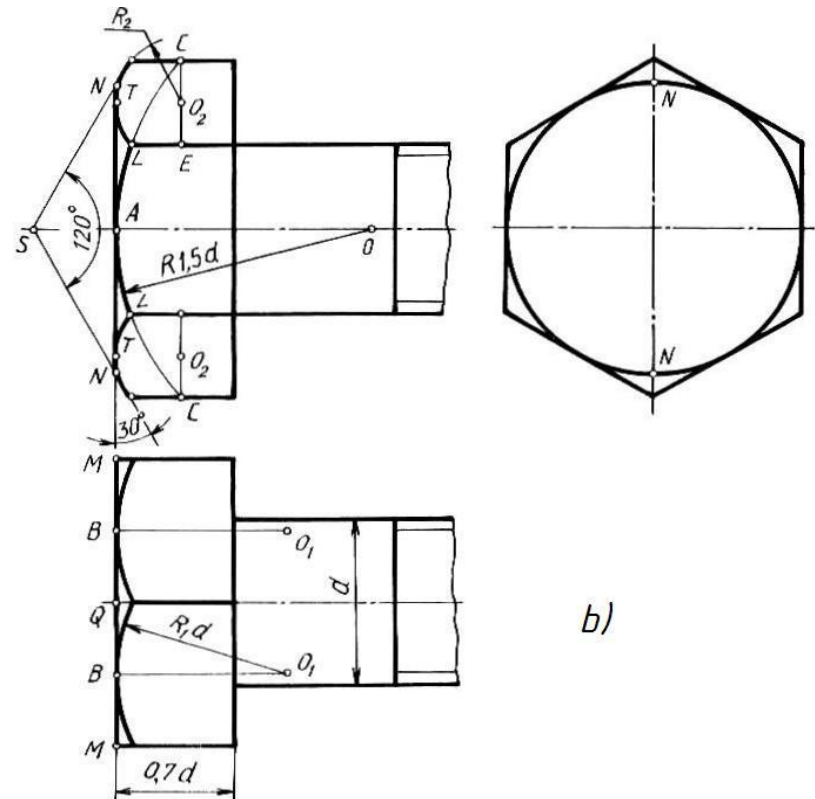
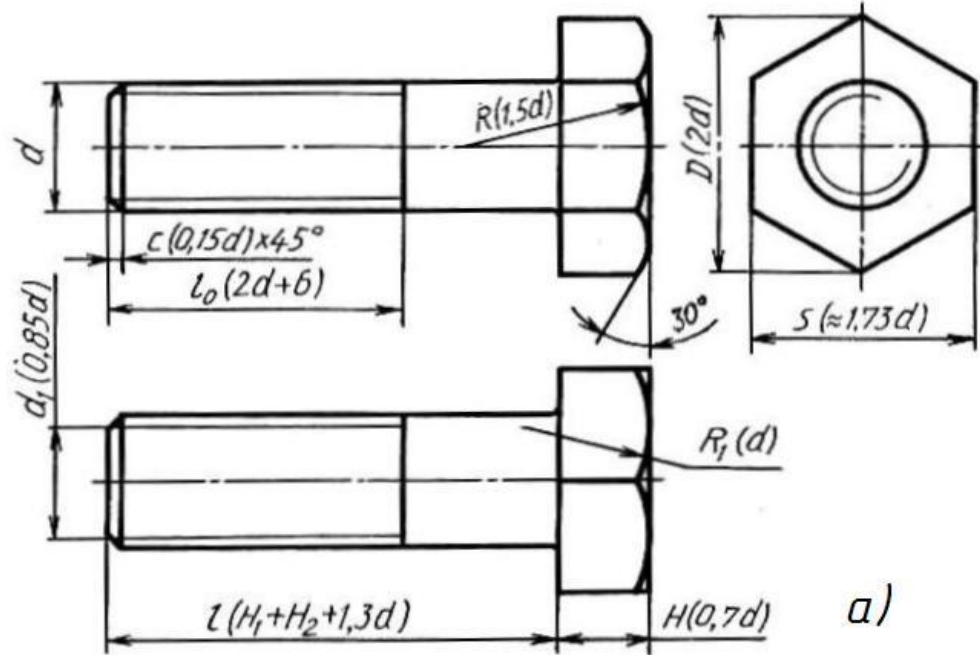

# REZBALI DETALLAR

## 2. Vint va shuruplar.

Bir uchida turli shakldagi kallagi bo'lgan, ikkinchi uchida rezba o'yilgan silindrik sterjendan iborat detalga **vint** deyiladi.

Vintning rezbasi biriktiriladigan detallarning biriga burab kirgiziladi. Vintlar ularning tatbiqiga qarab ikkiga, ya'ni **mustahkamlovchi va o'rnatuvchi** vintlarga bo'linadi.

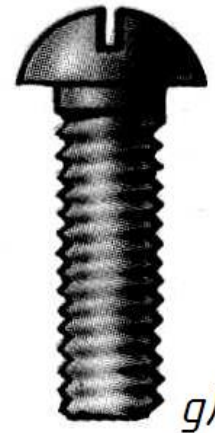
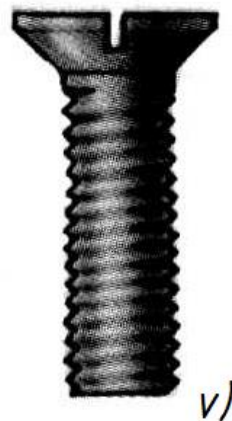
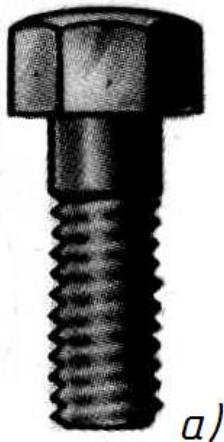
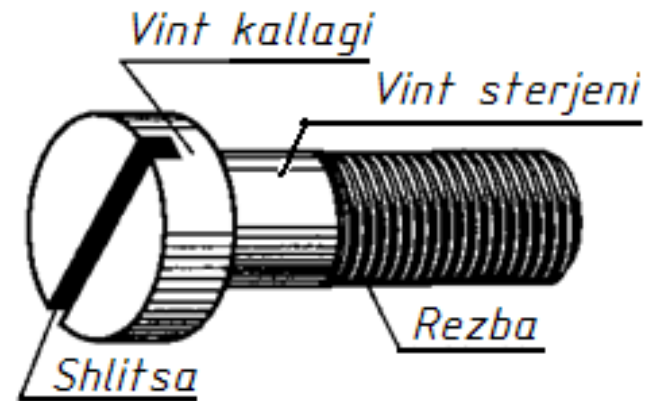

# REZBALI DETALLAR

## 2. Vint va shuruplar.

**Shuruplar.** Metallga mo'ljallangan vintlardan tashqari yog'och, plastmassa uchun mo'ljallangan vintlar ham bo'ladi. Yog'och va plastmassa materiallardan tayyorlangan buyumlarni biriktirish uchun mo'ljallangan vintlar *shuruplar* deyiladi

Shuruplarning kallagi yarim yumaloq, yashirin, yarim yashirin, olti qirrali va kvadrat shakllarda tayyorlanadi. Ularning kallagida burash uchun o'yiqlar mavjud.

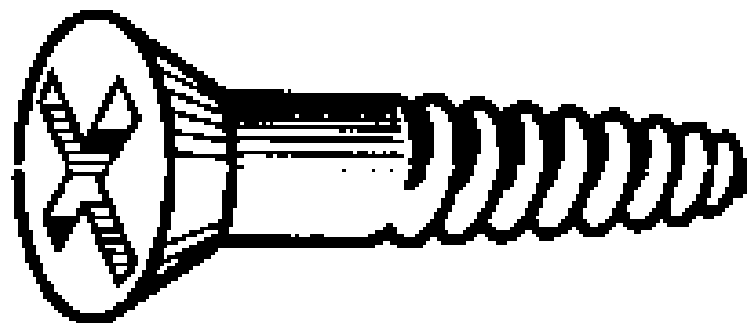
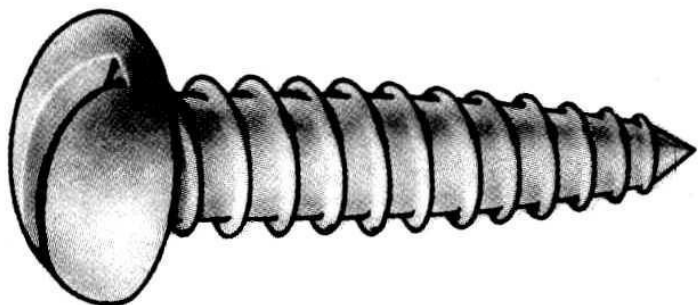

# REZBALI DETALLAR

## 3. Shpilkalar va shpilka uyasi.

Shpilka silindrik sterjen bolib, uning ikkala uchiga rezba o'yilgan bo'ladi. Uning kalta rezbali uchi biriktiriluvchi detallarning biriga burab kiritiladi, ikkinchi uchiga gayka burab kiritiladi.

Shpilkalardan konstruktiv nuqtayi nazardan boltlarni ishlatish mumkin bo'lmaydigan joylarda foydalaniladi. Ularning ikkala uchiga ham yirik va mayda qadamli metrik rezbalar o'yilgan bo'lishi mumkin.

Shpilkalar ikki xil A va B aniqlik sinfida tayyorlanadi. A aniqlikdagi sinfda - shpilka rezbasining nominal diametri va rezbasiz (silliq) sterjen qismining diametri bir xil ( $a$ ), B aniqlikdagi sinfda - shpilka rezbasining nominal diametri rezbasiz (silliq) sterjen qismining nominal diametridan katta ( $b$ ) bo'ladi.

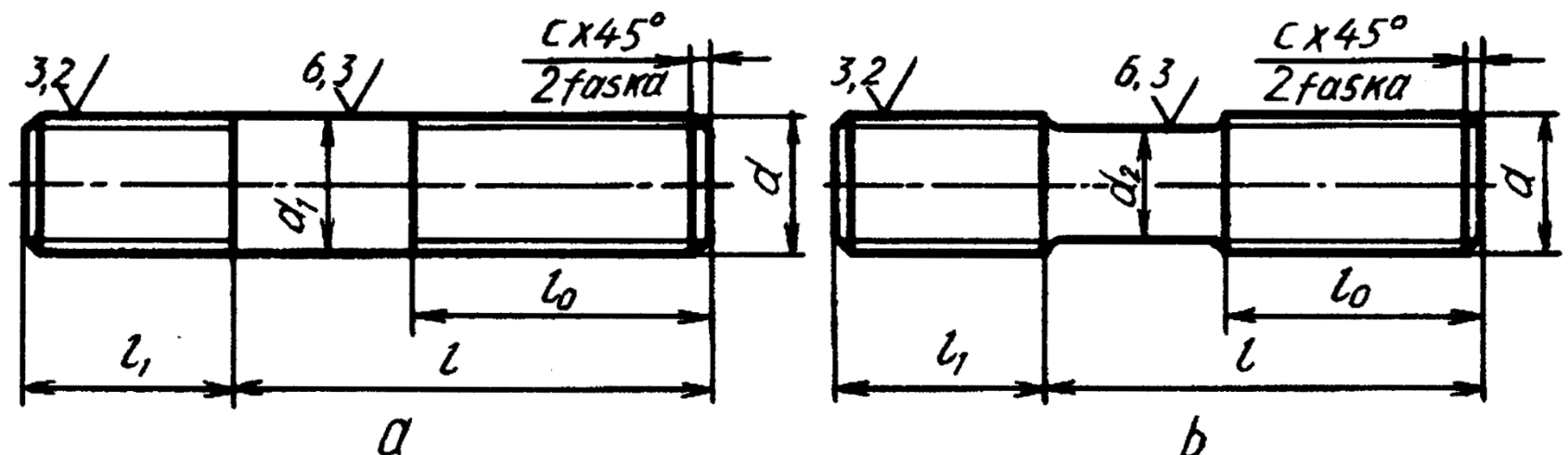

# REZBALI DETALLAR

## 3. Shpilkalar va shpilka uyasi.

Shpilkaning burab kiritiladigan  $l_1$  qismining uzunligi uning burab kiritiladigan uyasi (detal) qanday materialdan tayyorlanganligiga bog'liq. Kiritiladigan rezballi uya qattiq materialdan iborat bo'lsa,  $l_1=d$  va  $l_1=1,25 \times d$ , yumshoq materialga kiritiladigan bo'lsa,  $l_1=1,6 \times d$  va  $l_1=2,5 \times d$  qilib tayyorlanadi.

Shpilkaning uzunligi  $l$  (shpilka uzunligiga  $l_1$  masofa kirmaydi) shpilka kiydirilib mustahkamlanadigan detalning qalinligi  $H_1$  ga bog'liq bo'ladi, ya'ni  $l=H_1+1,3 \times d$  ga teng qilib olinadi. Shpilkaning belgilanishi. Rezba nominal diametri  $d = 20 \text{ mm}$ ., yirik qadamli  $P=2 \text{ mm}$ , qo'yim maydoni  $6g$ , uzunligi  $l=100 \text{ mm}$ , mustahkamlik sinfi  $5,8$  bo'lgan qoplamasiz shpilkaning shartli belgilanishiga misol:

**Shpilka M20-6g×100.58 GOST 22032-76.**

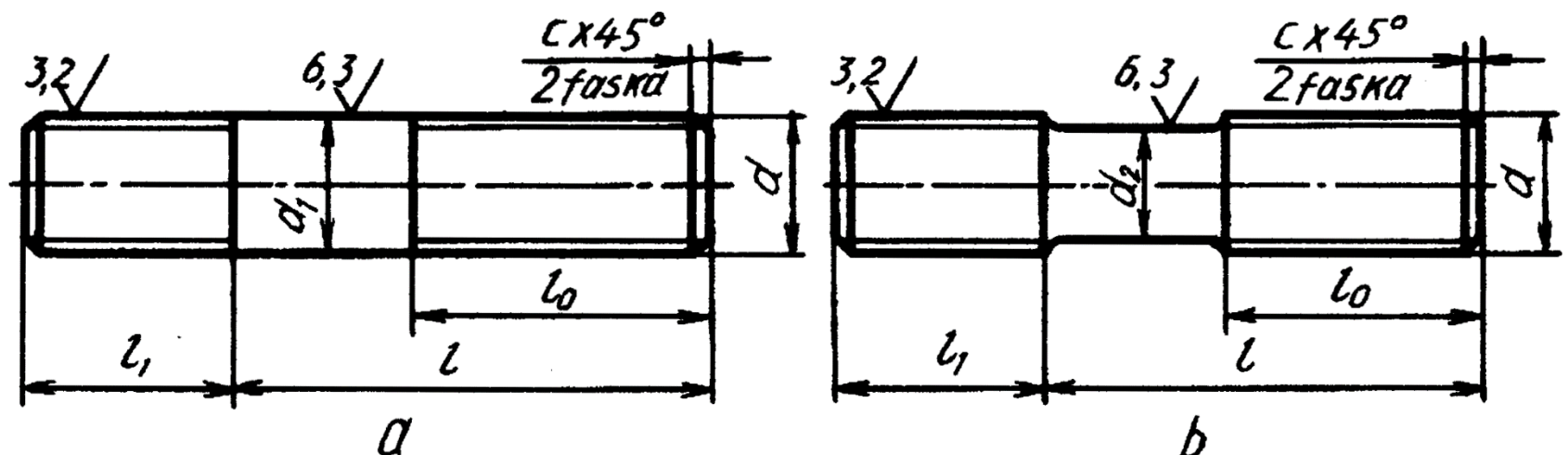

# REZBALI DETALLAR

## 3. Shpilkalar va shpilka uyasi.

Xuddi shu shpilkaning o'zi, qadami mayda  $P=1,5$  mm, qo'yimlar maydoni  $8g$ , mustahkamlik sinfi 10,9 va 40x markali po'latdan ishlangan. 0,2-sinf bo'yicha 6 mkm qalinlikda qoplangan shpilka quyidagicha belgilanadi:

**Shpilka 2M20×1,5-8g×100.109.40X.026 GOST 22032-76.**

Burab kiritiladigan qismi  $l_1=1,6×d$ , A sinf aniqlikdagi, 1-bajarilishdagi rezbasining diametri  $d=20$  mm, burab kiritiladigan qismidagi rezbasi mayda qadamli  $P=1,5$  mm, dopusk maydoni  $2r$ , gayka burab kiritiladigan rezbali uchining rezbasi qadami yirik  $P=2,5$  mm, dopusk maydoni  $6g$ , uzunligi 160 mm, mustahkamlik sinfi 6,6 va qoplamasi 0,5 bo'lgan shpilkaning shartli belgilanishiga misol:

**Shpilka M20×-(1,5/2r)×6g160.6,6.0,5.**

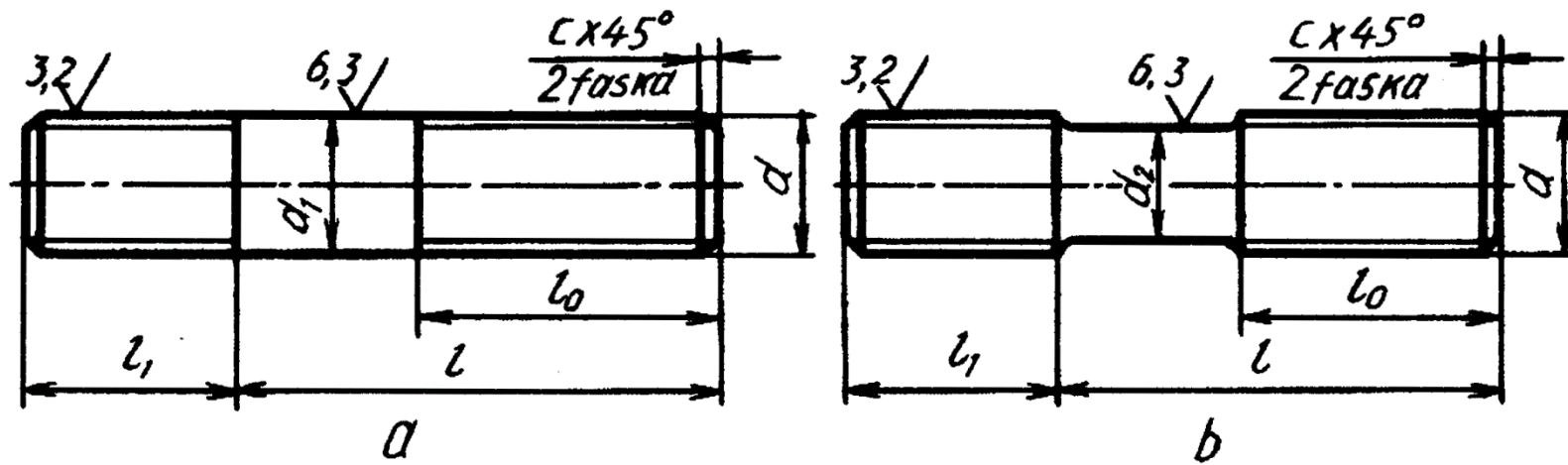

# REZBALI DETALLAR

## 3. Shpilkar va shpilka uyasi.

**Shpilka uyasi.** Shpilka burab kiritiladigan rezbali teshik shpilka uyasi deyiladi. Uya avval parma bilan rezba diametrining ichki diametriga, ya'ni  $d_1=0,85 \times d$  ga teng qilib,  $l=1,5 \times d$  o'yiladi. Uyaning tubidagi konus parma uchidagi konus izi bo'lib, u  $120^\circ$  ga teng. Keyin bu uyaga metchik yordamida rezba o'yiladi.

Shpilka uyasining chuqurligi uya ishlanadigan detaining materialiga bog'liq. Po'lat, bronza qattiq qotishmalar uchun uya chuqurligi  $1,5d \dots 1,75d$ , cho'yandan va boshqa yumshoq qotishmalardan ishlangan detallarda chuqurligi  $1,75d \dots 3d$  qilib o'yiladi.

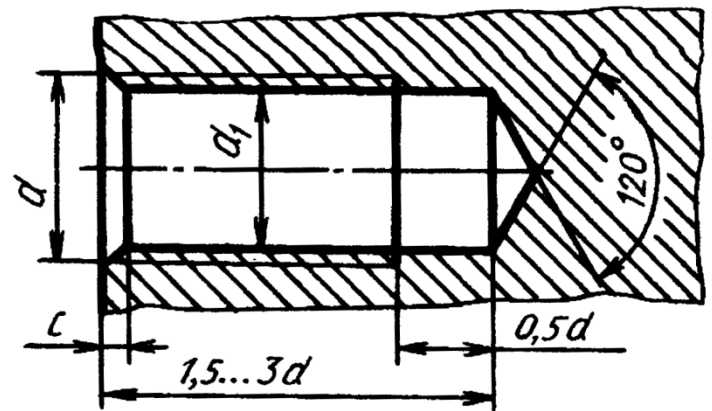
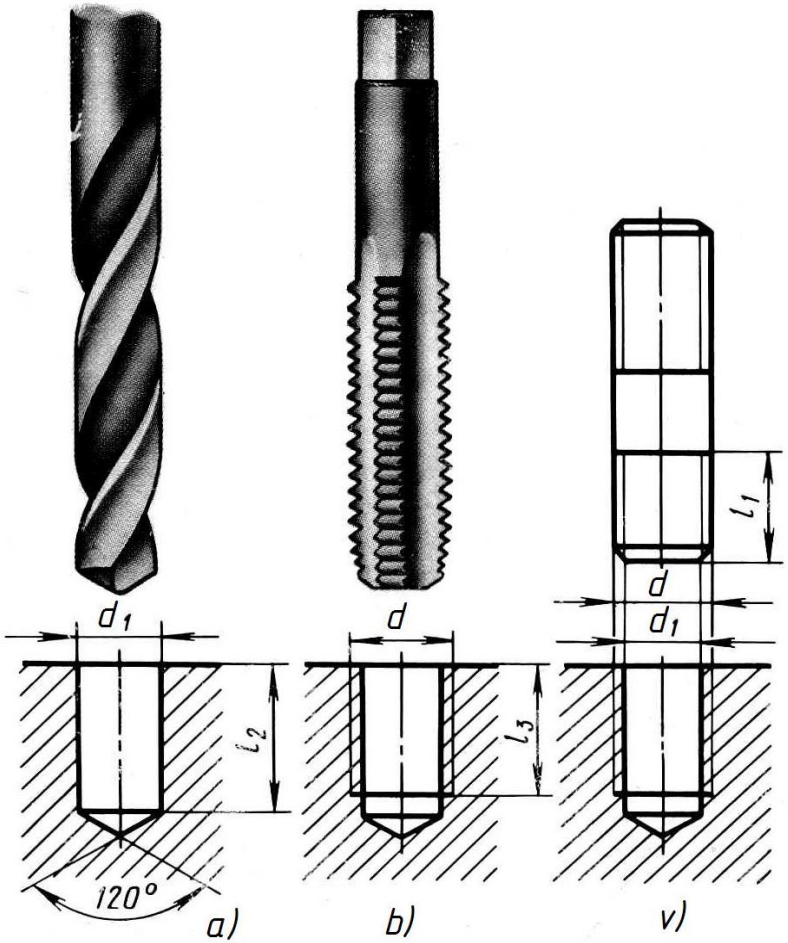



## REZBALI DETALLAR

4. **Gaykalar.** Bolt yoki shpilkaga burab kiritiladigan ichki rezba ochilgan detalga *gayka* deyiladi. Gayka olti qirra yoki kvadrat shaklida hamda gayka-barashka (qo'lda buraladigan quloqli gayka) ko'rinishida tayyorlanadi. 1.Olti qirrali. 2.Gayka-barashka. 3.Kesilgan. 4.Tojsimon. 5.Aylnasimon.

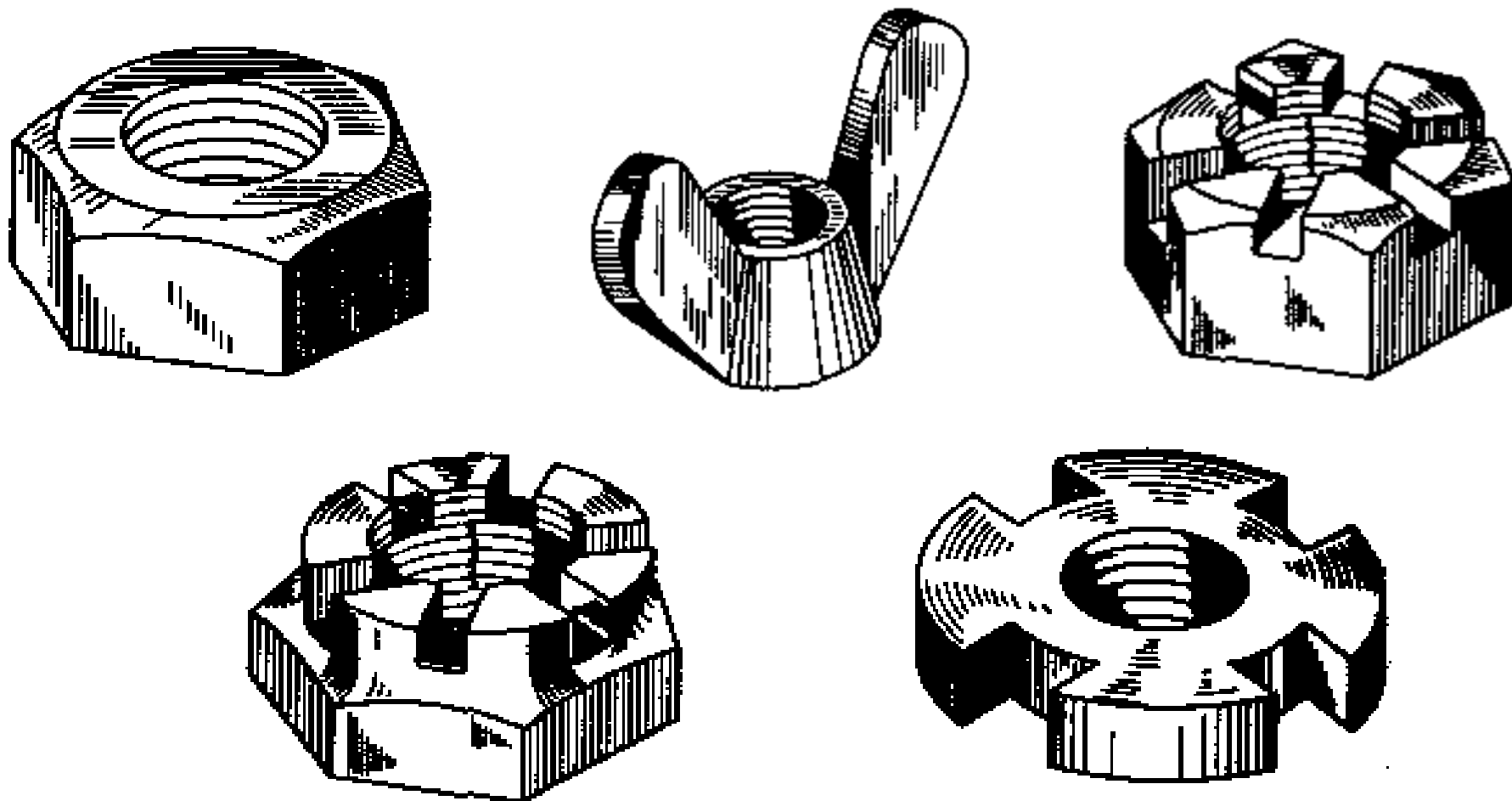

# REZBALI DETALLAR

**4. Gaykalar.** 1-bajarilishida ikki tomonlama tashqi konus faskalar ishlanadi (a);  
2-bajarilishida bir tomonlama konus faska ishlanadi (b);  
3-bajarilishida gayka toretsining bir tomonida silindrik yoki konussimon chiziq ishlanadi (c).

1-bajarilishdagi, rezbasining diametri  $d = 16$  mm, yirik qadamli  $P = 2$  mm, dopusk maydoni  $6H$ , mustahkamlik sinfi 5, qoplamasiz gaykaning shartli belgilanishiga misol:

**Gayka M16-6H.5 GOST 5915-70.**

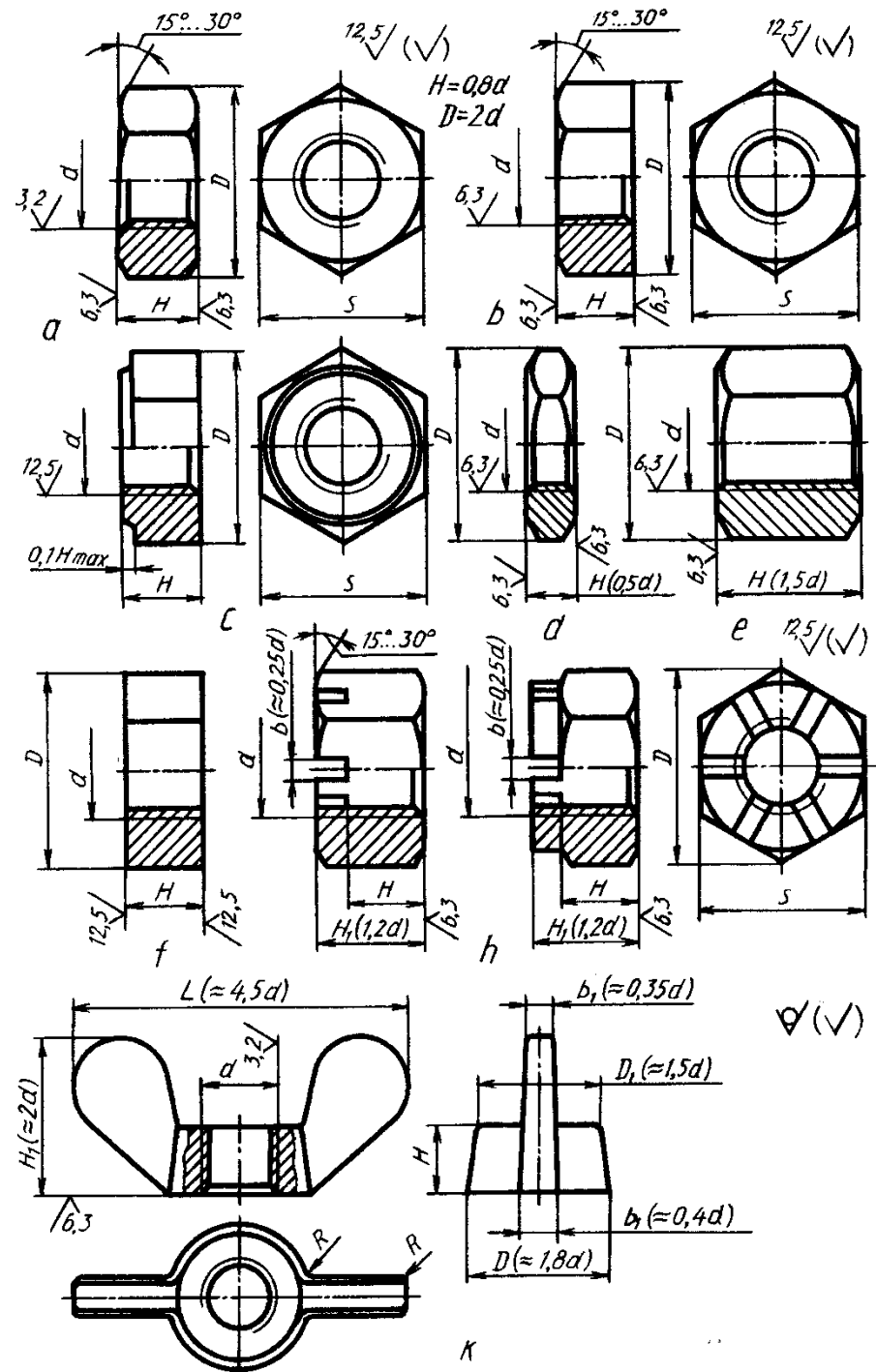

# REZBALI DETALLAR

4. Gaykalar. 2-bajarilishdagi, rezbasining diametri  $d=16$  mm, mayda qadamli  $P=1,5$  mm, dopusk maydoni  $6H$ , mustahkamlik sinfi 12, materiali 40x markali po'latdan tayyorlangan 0,1 qoplamali, qalinligi 9 mkm li gaykaning shartli belgilanishiga misol:

**Gayka 2M16x1,5-6H.12.40X.019 GOST 5915-70.**

Normal gaykalarni uning rezbasi  $d$  diametriga nisbatan taxminiy o'lchamlarda bolt kallagi kabi chizish mumkin. Bolt kallagidagi  $120^\circ$  li faska bir tomonlamma bo'lib, balandligi  $0,7 \times d$  olinsa, gaykada ikki tomonlamma  $120^\circ$  li faska chiziladi va balandligi  $H=0,8 \times d$  qilib olinadi.

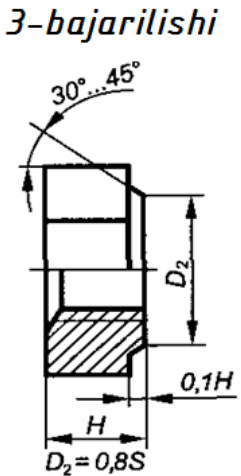
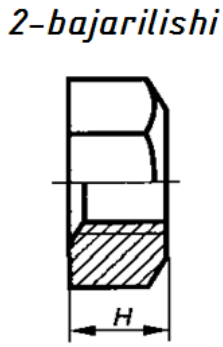
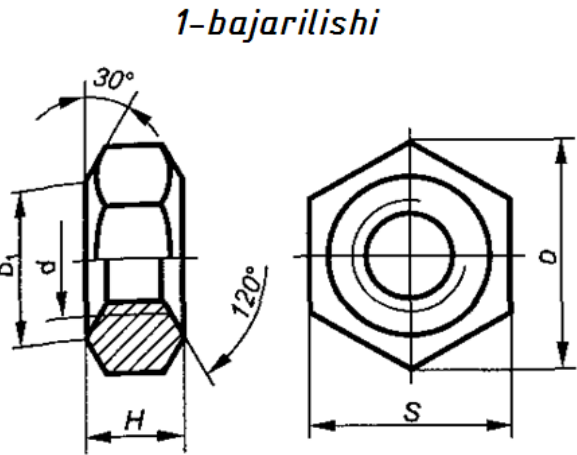
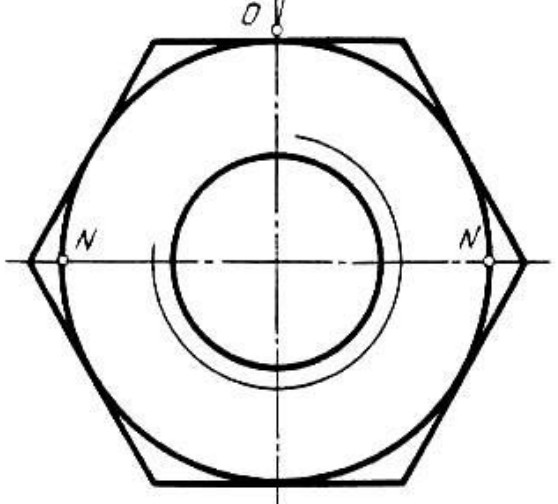
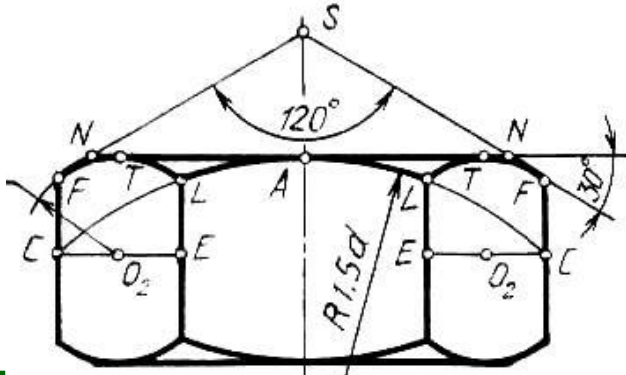

## REZBALI DETALLAR

**5. Shaybalar.** Shayba asosan gayka, vint yoki bolt kallagi ostiga qo'yiladi va ularning teshigida rezbasi bo'lmaydi. Ular biriktiruvchi va biriktiriluvchi detallarning yuzalarini buzilishdan saqlaydi hamda ularga ta'sir qiladigan zo'riqishni bir me'yorda uzatish va tarqatish uchun xizmat qiladi. Shaybalar *xomaki va toza* turlarga bo'linadi.

*Xomaki shaybalar* asosan list po'latdan qirqib tayyorlanadi va barabanda tozalanadi hamda ularga stanokda ishlov berilmaydi. *Toza shaybalar* bolg'alangan po'latdan stanokda tayyorlanadi hamda ularning o'rtasi va tashqi sirtida faskalari bo'ladi. Toza va xomaki shaybalardan tashqari, yana zarb, tebranish yoki silkinishlar ta'sirida gaykalar o'z-o'zidan buralib ketishidan saqlash uchun *prujina shaybalar* (GOST 6402-70) ishlatiladi.

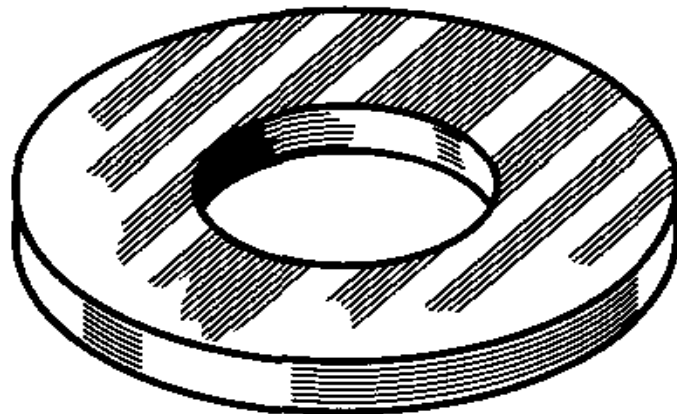

# REZBALI DETALLAR

## 5. Shaybalar.

1-bajarilishdagi teshik diametri  $d=14$  mm, 0,1-gruppacha materiali (0,8 kp markali po'lat)dan tayyorlangan qoplamasi qalinligi 6 mkm bo'lgan shaybaning shartli belgilanishiga misol:

**Shayba 14.01.08 kp.016**  
**GOST11371-78.**

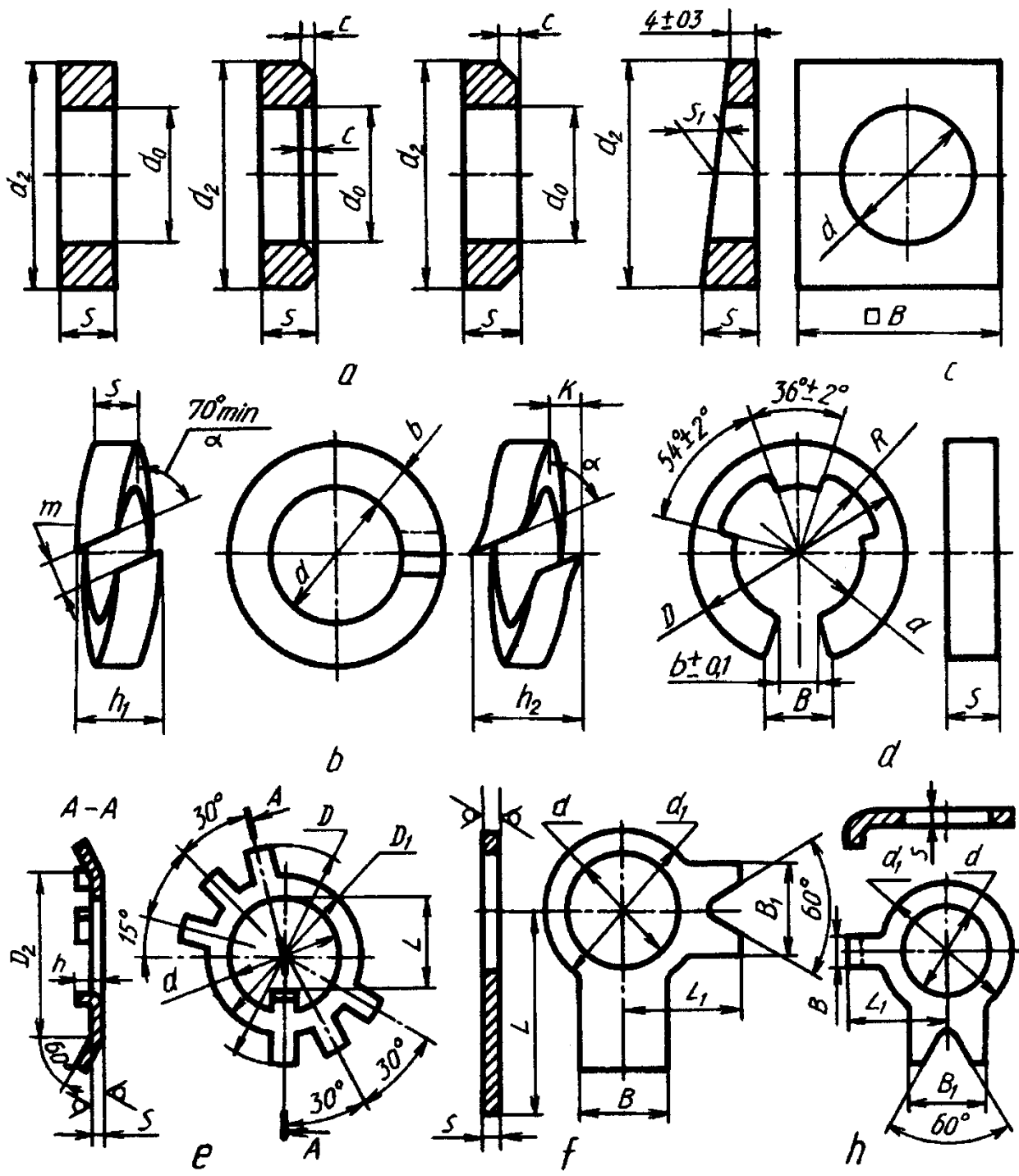

# REZBALI DETALLAR

## 5. Shaybalar.

Bundan tashqari to'xtatuvchi kurakchali shaybalar (GOST 13463—77\*) ham mavjud (a) bo'lib, undan ham ajraluvchi birikmalarni hosil qilishda foydalaniladi (b).

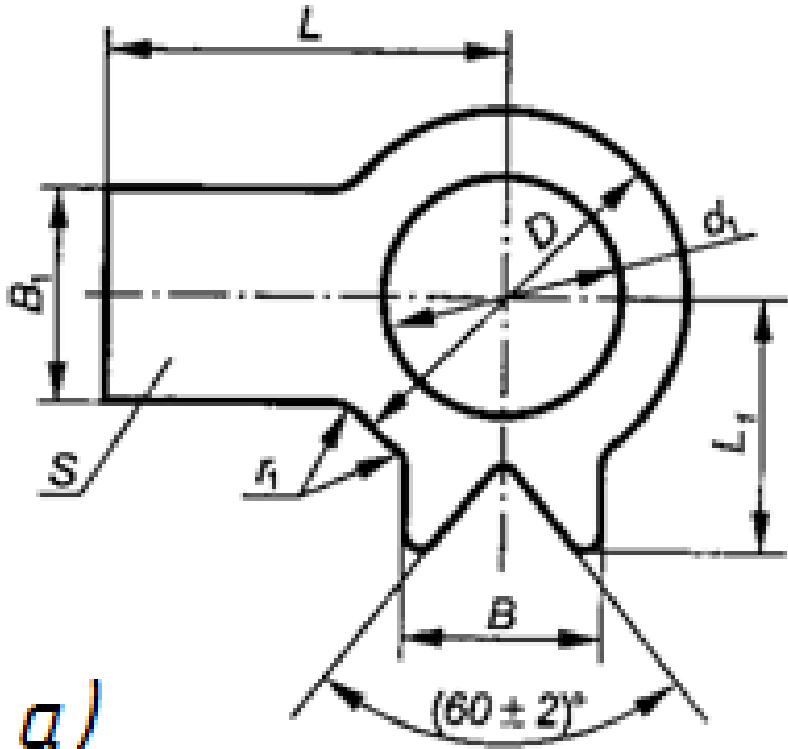

a)

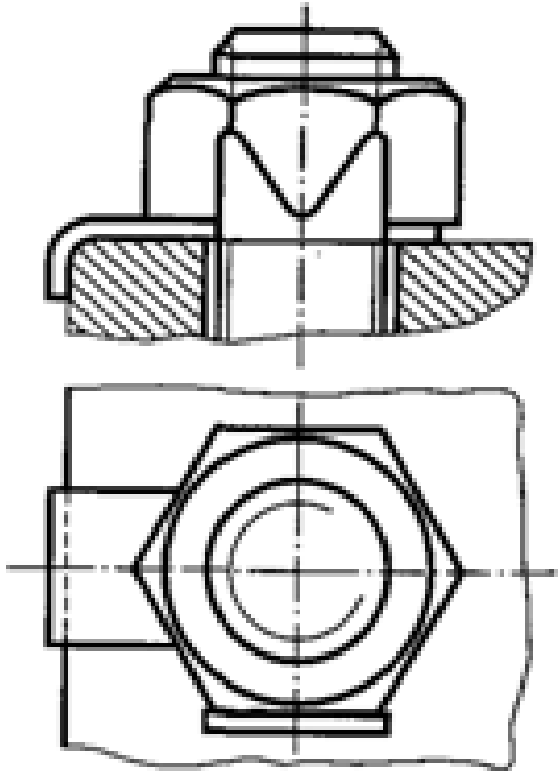

b)

*Uzunlashtirilgan*

## REZBALI DETALLAR

### 6. Fitinglar.

**To'g'ri muftalar.** Muftalar kalta (GOST 8954-75), uzun (GOST 8955-75) va kompensatsiya qiluvchi (GOST 8956-75) muftalar ko'rinishida ishlanadi. Bu muftalar bir-biridan faqat uzunliklari bilan farq qiladi.

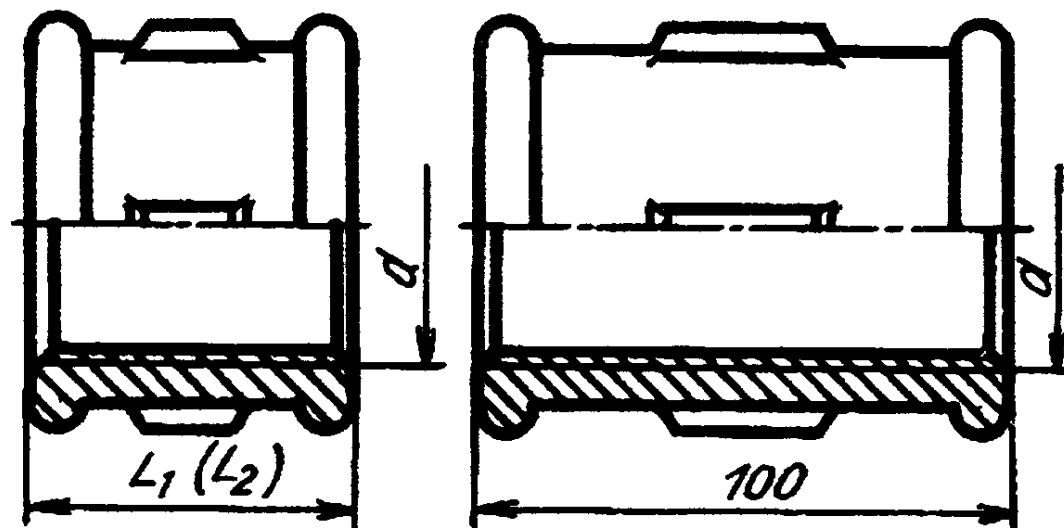

**O'tish muftalari** (GOST 8957-75). Bunday muftalarning bir tomoni ikkinchi tomoniga nisbatan katta yoki kichik diametrlarni o'tuvchi qilib tayyorlanadi.

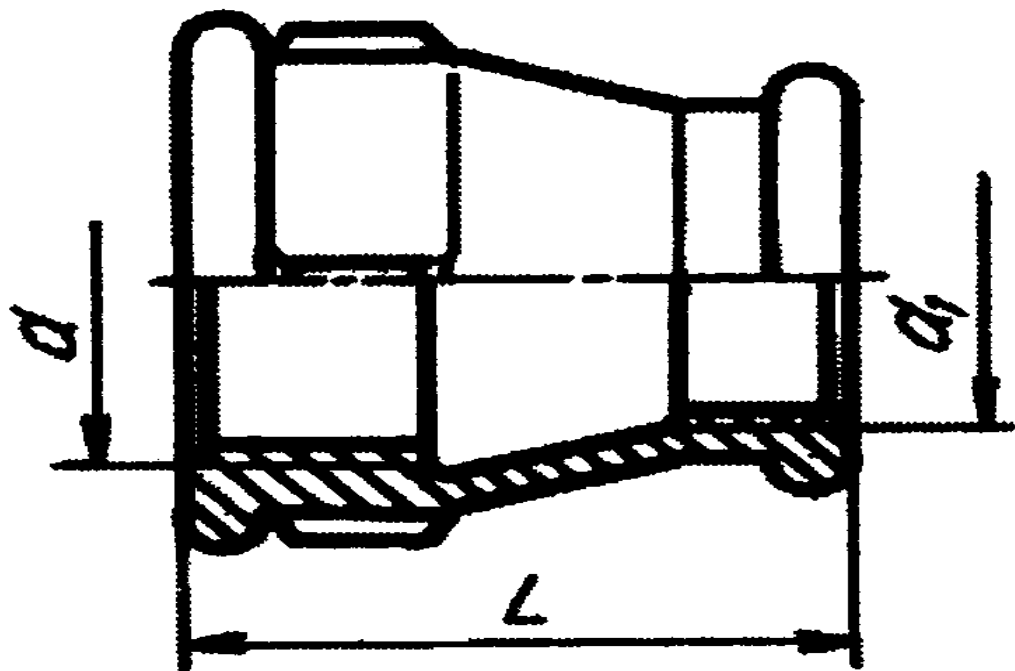

# REZBALI DETALLAR

## 6. Fitinglar.

Tirsakli muftalar (GOST 8947-75). Bunday muftalar ikki xil ko'rinishda ishlanadi. 1- bajarilishida tirsakning ikkala uchiga truba burab kiritilsa (a), 2-bajarilishining bir tomoniga truba, ikkinchi uchiga fitting burab kiritiladi (b). To'g'ri tirsaklardan tashqari o'tkir hamda o'tmas burchakli tirsaklar ishlab chiqariladi.

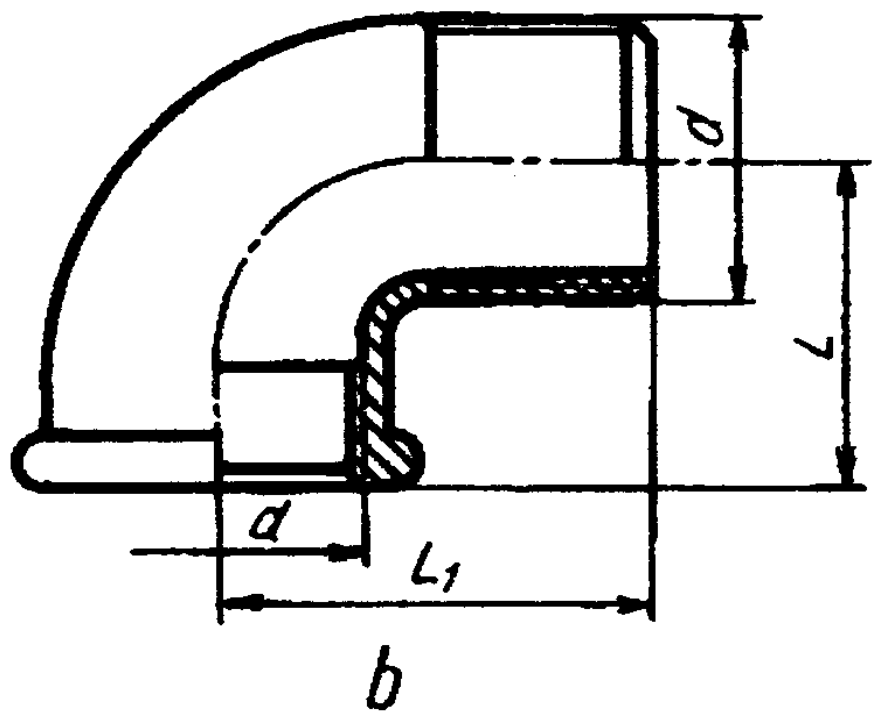
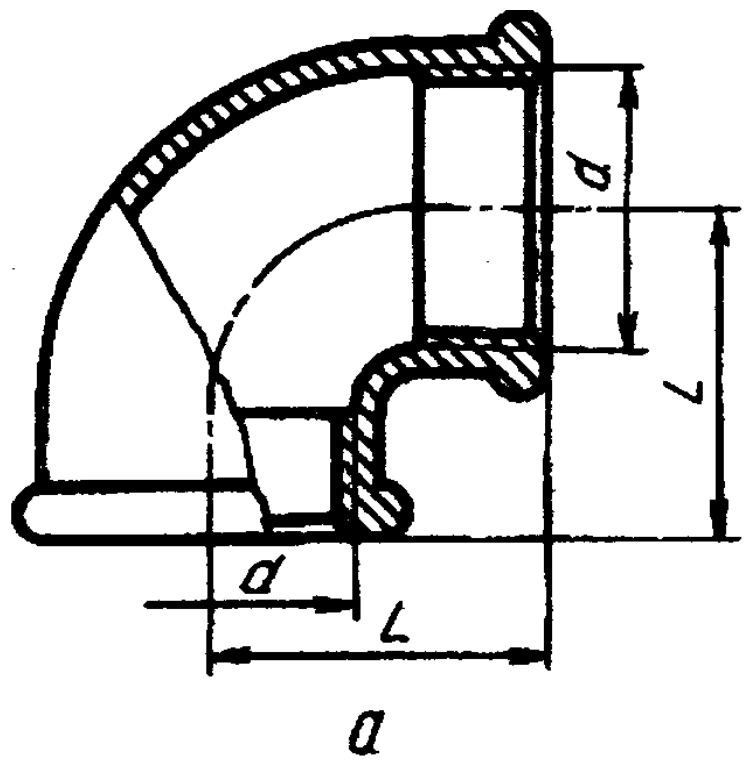



# REZBALI DETALLAR

## 6. Fitinglar.

**Troyniklar.** Troyniklar to'g'ri (GOST 8948-75) va o'tish troyniklari (GOST 8950-75) ko'rinishida tayyorlanadi. Bir xil diametrli 3ta trubani o'zaro birlashtirishda to'g'ri troyniklardan, uchala rezbali teshiklarining o'lchamlari har xil bo'lsa o'tish troyniklaridan foydalaniladi.

**Krestlar.** To'g'ri (GOST 8951-75), o'tish (GOST 8952-75) krestlari ishlab chiqariladi. To'g'ri krestlarda to'rttala rezbali teshik o'lchamlari bir xil bo'lsa, o'tish krestlarida har xil bo'ladi.

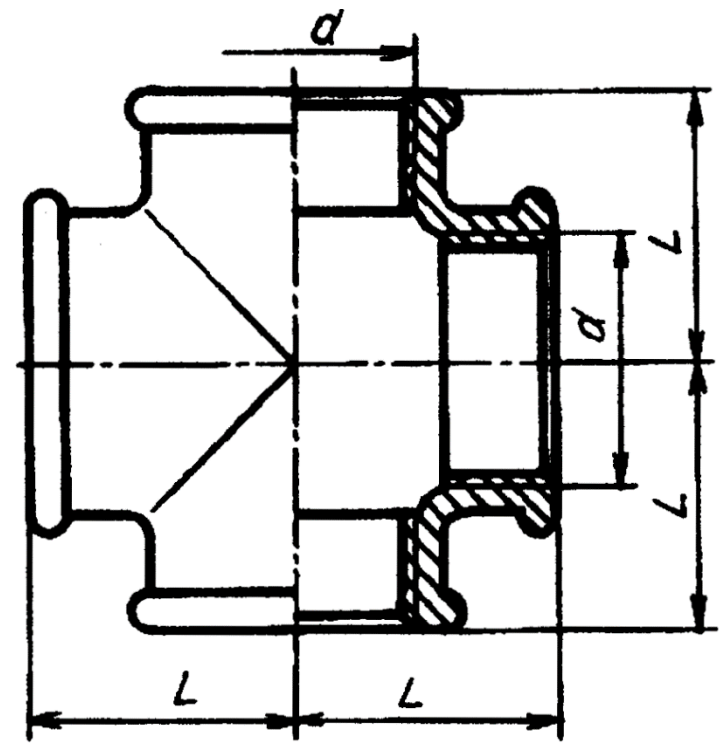
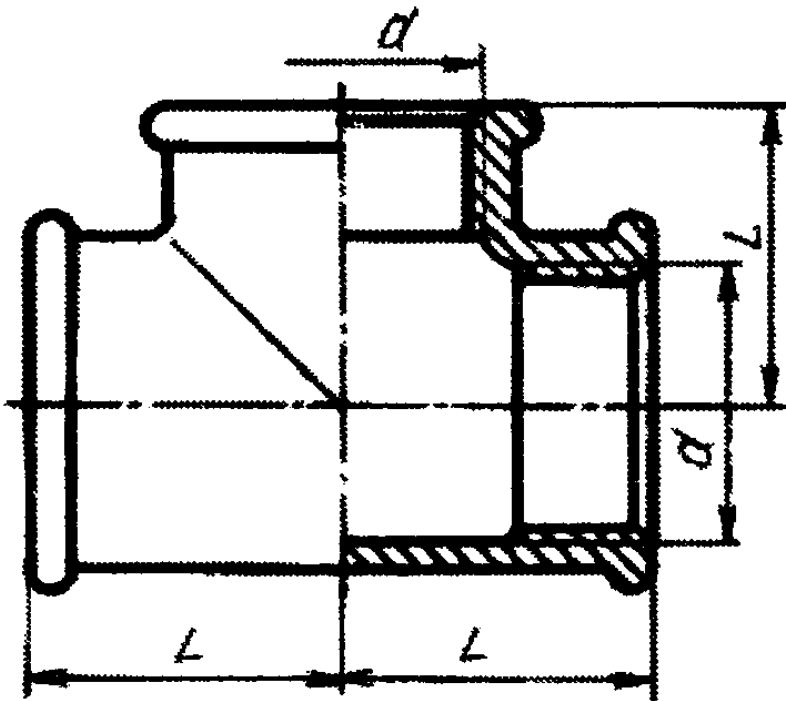

# REZBALI DETALLAR

## 6. Fitinglar.

Qopqoqlar (GOST 8962-75). Trubalarning uchlarini berkitish uchun qopqoqlar ishlanadi, ular ikki xil ko'rinishda bajariladi. 1-bajarilishida yumaloq yopiq gayka (a), 2-bajarilishida olti qirrali yopiq gayka (b) kabi ishlab chiqariladi.

Fitinglarning teshiklarini berkitish uchun (GOST 8963-75) tiqinlardan ham foydalaniladi.

**Kontrgaykalar.** Trubali birikmalarda gaz yoki suyuqlik sizib chiqishining oldini olish maqsadida kanop tolasidan o'ralgan moyli zichlagichlarni zichlash uchun kontrgaykalar (GOST 8961-75) ishlatiladi. Kontrgaykaning o'lchamlari fittinglar kabi standartlashtirilgan.

